

# Original BMW Parts and Accessories.

## Installation Instructions.



### Electric Pivot-Mounted Trailer Tow Hitch Retrofit.

**BMW 5 Series Saloon (G30)**

**BMW 5 Series Touring (G31)**

**BMW M5 (F90)**

**BMW 6 Series Grand Tourer (G32)**

#### Retrofit kit number

71 60 6 888 468 Trailer tow hitch kit, electrically pivot-mounted

71 60 6 875 627 Trailer tow hitch kit, electrically pivot-mounted

71 60 2 448 621 Electrical add-on parts retrofit kit

#### Installation time

The installation time is **approx. 4.0 hours**. This may vary depending on the condition of the car and its equipment package.

On cars without SA 8SL the underfloor positive battery cable must be replaced. This increases the installation time by **approx. 4.0 hours**.

The installation time shown does not include any time spent on programming/coding.

The calculation of the total costs for the programming time must be factored into the calculation of retrofitting costs (must not be invoiced under the warranty).

#### Important information

These installation instructions are primarily designed for use within the BMW dealership organisation and by authorised BMW service companies.

These installation instructions are intended for use by qualified specialist staff trained on BMW cars with the relevant expert knowledge.

All work must be completed using the latest BMW repair manuals, wiring diagrams, servicing manuals and work instructions, in a logical order, using the prescribed tools (special tools), and observing current health and safety regulations.

With the exception of PHEV cars, the positive underfloor battery cable must always be replaced to withstand the higher loads.

**If you experience installation or functional problems, restrict troubleshooting to approx. 0.5 hours for mechanical work and 1.0 hours for electrical work.**



To avoid unnecessary extra work and/or costs, please send an inquiry to the technical parts support team.

Quote the following information:

- VIN,
- retrofit kit part number,
- a detailed description of the problem,
- any work already carried out.

Please do not archive the printout of these installation instructions. The current version can be found in the EPC.

## Pictograms

-  Denotes instructions that draw your attention to dangers.
-  Denotes instructions that draw your attention to special features.
- ◀ Denotes the end of the instruction or warning text.

## Legal requirements

There is a type approval for the trailer tow hitch pursuant to **ECE-R55** with approval reference **E13\*55R-014124**.

These installation instructions also serve as installation confirmation. They must be printed and attached to the vehicle documents and kept in the car at all times until the trailer tow hitch has been entered in the vehicle documents.

## Installation information

 The fan frame with fan will need to be replaced on certain models of vehicle (see ordering instructions). If you do not replace the electric fan, the towing capacity will be reduced and the engine may stop.

Ensure that the cables and/or lines are not kinked or damaged as you install them in the car. Costs arising from this will not be reimbursed by BMW AG.

Additional cables/wires that are installed must be secured with cable ties. If the specified PIN chambers are occupied, bridges, double crimps, or twin-lead terminals must be used.

All illustrations show LHD (left-hand drive) cars; proceed in the same way on RHD (right-hand drive) cars.

After the installation work, the retrofit must be programmed/coded via the – **Retrofits** – path.

## Replace the fuse box

If factory-installed rear fuse box **Z2** does not contain plugs **Z2\*8B** and **Z2\*9B**, rear fuse box **F** must be installed.

## Ordering instructions

The following parts are not supplied in the retrofit kit and must be ordered separately (see EPC for part number and details):

- AAG control unit **D**
- Rear fuse box **F**
- LIN module power distributor **G**
- Underfloor positive battery cable **V**
- Emergency unlocking mechanism finisher **U**
- Fan frame with fan **W**

The fan frame and fan and the coolant cooler/repositioned coolant cooler may need to be replaced. If a “fan frame and fan” and the “coolant cooler/repositioned coolant cooler” is listed in the table in main group 17 as an option for the trailer tow hitch, this part number must also be ordered and installed. If the fan has to be replaced, use the module and power distributor from the table in the EPC.

## List of options

The following special equipment must be used during the installation work:

- SA 2VH** Integral active steering
- SA 2VA** Adaptive drive
- SA 322** Comfort Access
- SA 823** Hot country version
- SA 8SL** Trailer tow hitch preparation

**Special tools required**

Refer to the relevant ISTA/AIR repair manual for details of the special tool required.

## Table of contents

Section	Page
1. Parts list for retrofit kit .....	5
2. Preparatory work .....	6
3. Retrofit wiring harness connection diagram .....	7
4. Bus interface connection diagram .....	8
5. Overview of connections for underfloor positive battery cable (cars without SA 8SL only) .....	9
6. Installation and cabling diagram .....	10
7. Installation and routing diagram for underfloor positive battery cable (cars without SA 8SL only) .....	11
8. Installing the trailer tow hitch and connecting the retrofit wiring harness .....	12
9. Replace underfloor positive battery cable (cars without SA 8SL only) .....	20
10. Concluding work and coding .....	22
11. Wiring diagram .....	23
12. Template (G30, F90 only) .....	25
13. Template (G31, G32 only) .....	26
14. Coupling ball clearances and installation height for towing ball coupling .....	27
15. Statutory regulations under ECE Directive R55 .....	28

## 1. Parts list for retrofit kit

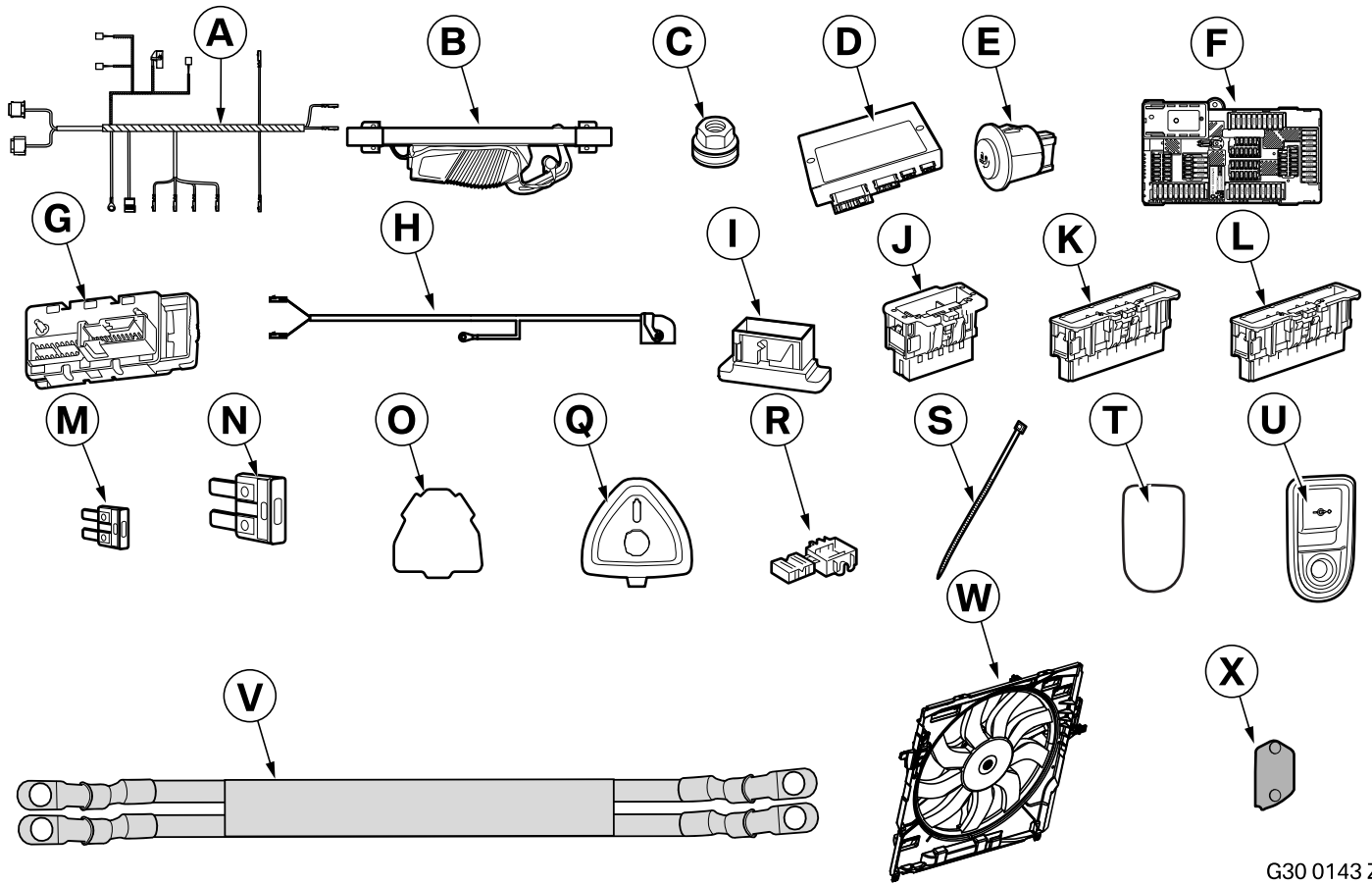

G30 0143 Z

### Legend

- A** Retrofit wiring harness
- B** Trailer tow hitch
- C** M12 hexagon screw (4 x)
- D** AAG control unit (not supplied in the retrofit kit)
- E** Trailer tow hitch switch
- F** Rear fuse box (not supplied with the retrofit kit)
- G** LIN module power distributor (not supplied in the retrofit kit)
- H** Bus interface retrofit wiring harness
- I** Bus interface
- J** GN 12-pin socket housing
- K** VI 10-pin socket housing
- L** GN 10-pin socket housing
- M** Mini 20 A fuse (2 x)
- N** ATO 20 A fuse Q (2 x)
- O** Template (G30 only)
- Q** Emergency unlocking mechanism trim (G30 only)
- R** 2-way miniature connector (2 x)
- S** Cable ties (15 x)
- T** Template (G31, G32 only)
- U** Emergency release trim (G31, G32 only; not supplied in the retrofit kit)
- V** Underfloor positive battery cable (not supplied in the retrofit kit)
- W** Fan frame with fan (not supplied with the retrofit kit)
- X** Gasket

## 2. Preparatory work

	<b>ISTA/AIR No.</b>
Disconnect all negative battery cables	61 20 900
Release and disconnect various plug connections	61 13 ...
Cut, strip and crimp cables	61 11 ...
Open the plug housing and remove the contacts from various connection systems	61 13 ...
Instructions for handling wiring harnesses and cables	61 00 ...
Instructions for handling the documents: Repair manual, technical data, tightening torques	00 11 ...
<b>The following components must be removed first of all</b>	
Rear bumper trim	51 12 156
Support for rear bumper trim (no longer required)	51 12 828
Luggage compartment wheel arch trim, right	51 47 161
Rear seat backrest side section, right (release)	52 26 008
Rear right (interior) door sill cover strip	51 47 030
Bottom right dashboard trim	51 45 195
Trim for right door pillar (bottom)	51 43 150
Front right (interior) door sill cover strip	51 47 000
Right footwell side trim (A-pillar)	51 43 070
<b>Cars without SA 8SL only</b>	
Right underbody panelling	51 71 018
Right wheel arch trim	51 71 040
Rear axle (lower only)	33 34 ...
Fuel tank (lower only)	16 11 030
<b>Only cars with B58 engine without SA 8SL</b>	
Replace the fan frame with fan	17 11 035

### 3. Retrofit wiring harness connection diagram

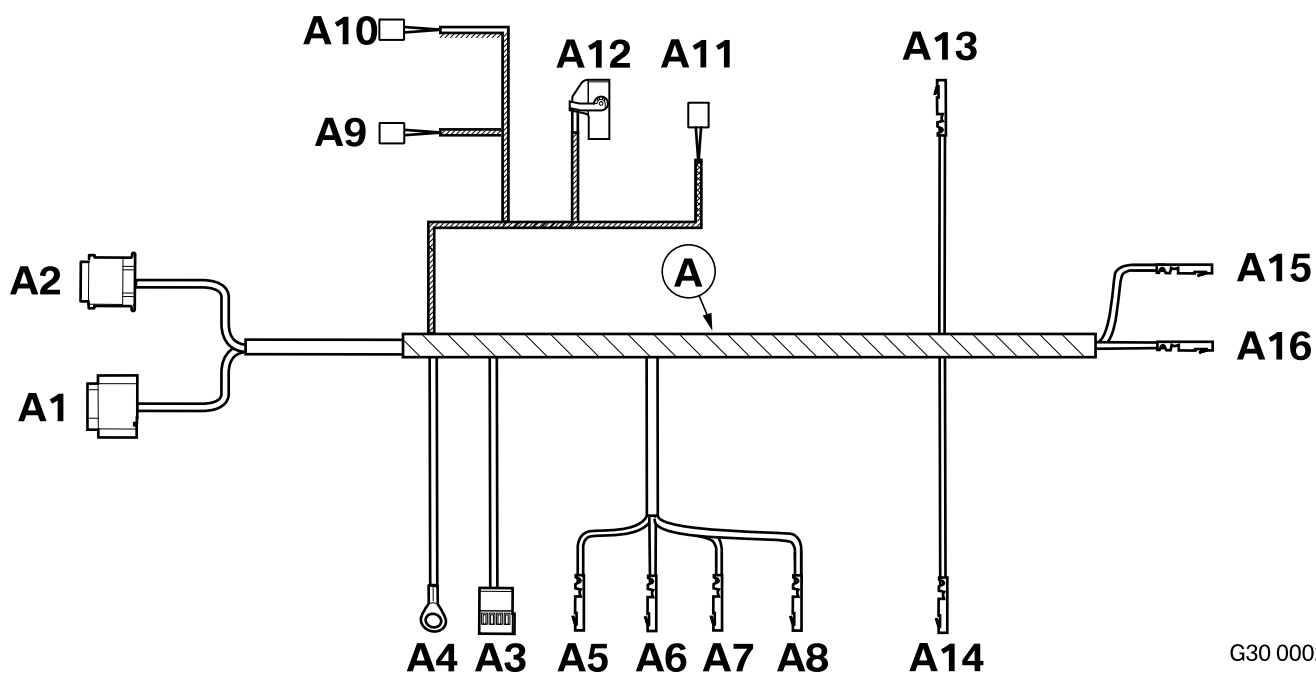

Item	Designation	Signal	Cable colour/ Cross-section	Connection location in the car	Abbreviation/ Slot
A	Retrofit wiring harness	---	---	---	---
A1	SW 12-pin socket housing	---	---	To trailer tow hitch <b>B</b>	X269*1B
A2	SW 6-pin socket housing	---	---	To trailer tow hitch <b>B</b>	X268*1B
A3	WS 6-pin socket housing	---	---	Trailer tow hitch button <b>E</b>	S71*1B
A4	Eyelet	Terminal 31	BR 0.25 mm <sup>2</sup>	Rear right luggage compartment ground support point <b>Z10</b>	Z10*12B
A5	Socket contact	Terminal 30B	RT/GE 1.5 mm <sup>2</sup>	Rear right fuse box <b>Z2</b>	Z2*8B PIN 11
A6	Socket contact	Terminal 30B	RT/SW 1.5 mm <sup>2</sup>	Rear right fuse box <b>Z2</b>	Z2*8B PIN 9
A7	Socket contact	Terminal 30F	RT/BR 1.5 mm <sup>2</sup>	Rear right fuse box <b>Z2</b>	Z2*9B PIN 8
A8	Socket contact	Terminal 30F	RT/VI 1.5 mm <sup>2</sup>	Rear right fuse box <b>Z2</b>	Z2*7B PIN 1
A9	GR 10-pin socket housing	---	---	To AAG control unit <b>D</b>	A255*4B
A10	SW 10-pin socket housing	---	---	To AAG control unit <b>D</b>	A255*3B
A11	SW 6-pin socket housing	---	---	To AAG control unit <b>D</b>	A255*2B
A12	SW 24-pin socket housing	---	---	To AAG control unit <b>D</b>	A255*1B
A13	Socket contact	BL_M	SW 0.35 mm <sup>2</sup>	To BDC control unit <b>A258</b>	A258*5B PIN 32
A14	Socket contact	FRA_Z_R	BL/GE 0.35 mm <sup>2</sup>	To BDC control unit <b>A258</b>	A258*3B PIN 37
A15	Socket contact	K_CAN2_H	GE/BR 0.35 mm <sup>2</sup>	To bus interface <b>R2/I</b>	R2*1B PIN 5
A16	Socket contact	K_CAN2_L	GE/RT 0.35 mm <sup>2</sup>	To bus interface <b>R2/I</b>	R2*1B PIN 18

## 4. Bus interface connection diagram

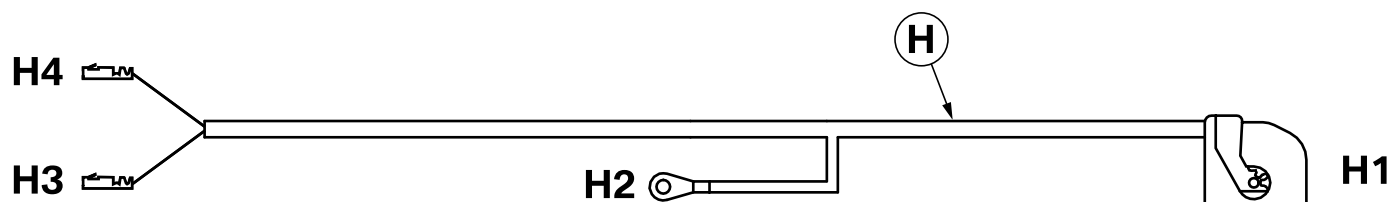

G30 0003 Z

Item	Designation	Signal	Cable colour/ Cross-section	Connection location in the car	Abbreviation/ Slot
H	Bus interface retrofit wiring harness	---	---	---	---
H1	SW 26-pin socket housing	---	---	To bus interface I	---
H2	M6 ring eyelet	Terminal 31	BR 0.35 mm <sup>2</sup>	To ground support point <b>Z10</b> on the right B-pillar	Z10*46B
H3	Socket contact	B2-CAN_H	GE/BR 0.35 mm <sup>2</sup>	To BDC <b>A258</b>	A258*8B PIN 50
H4	Socket contact	B2-CAN_L	GE/RT 0.35 mm <sup>2</sup>	To BDC <b>A258</b>	A258*8B PIN 49

## 5. Overview of connections for underfloor positive battery cable (cars without SA 8SL only)

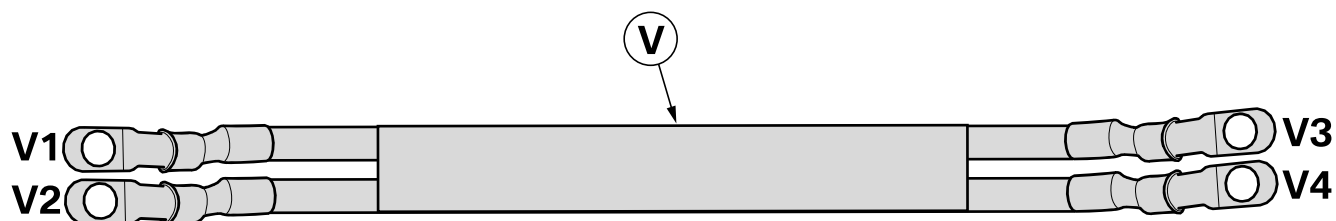

G30 0004 Z

Item	Designation	Signal	Cable colour/ Cross-section	Connection location in the car	Abbreviation/ Slot
V	Underfloor positive battery cable	---	---	---	---
V1	M8 ring eyelet	B+	RT 8.5 mm <sup>2</sup>	B+ engine compartment distributor <b>Z4</b>	Z4*1B
V2	M8 ring eyelet	B+	RT 8.5 mm <sup>2</sup>	B+ engine compartment distributor <b>Z4</b>	Z4*4B
V3	M8 ring eyelet	B+	RT 8.5 mm <sup>2</sup>	B+ battery distributor <b>Z3</b>	Z3*3B
V4	M8 ring eyelet	B+	RT 8.5 mm <sup>2</sup>	B+ battery distributor <b>Z3</b>	Z3*2B

## 6. Installation and cabling diagram

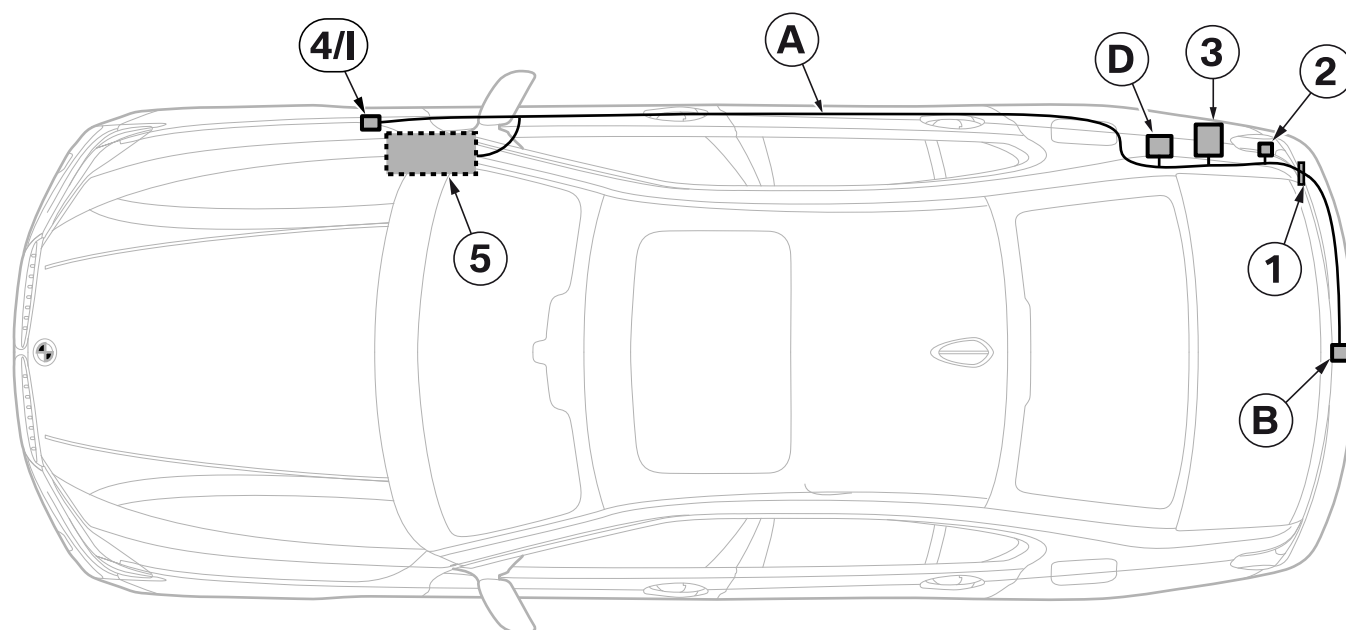

G30 0005 Z

- A** Retrofit wiring harness
- B** Trailer tow hitch
- D** AAG control unit
- I** Bus interface **R2** (only for cars without bus interface **R2** already installed)
  
- 1** Rubber grommet
- 2** Ground support point **Z10\*12B**
- 3** Rear right fuse box **Z2**
- 4** Bus interface **R2** (only for cars with bus interface **R2** already installed)
- 5** BDC **A258**

7. Installation and routing diagram for underfloor positive battery cable (cars without SA 8SL only)

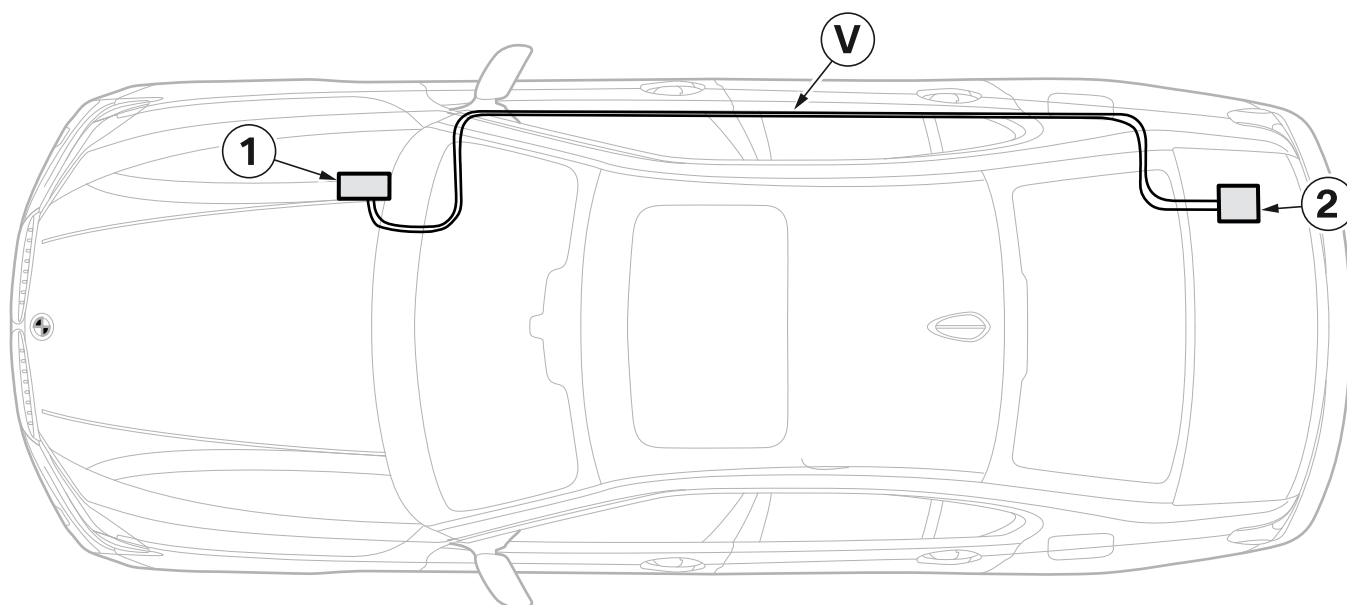

G30 0006 Z

- V** Underfloor positive battery cable
- 1** B+ engine compartment distributor **Z4**
- 2** B+ battery distributor **Z3**

## 8. Installing the trailer tow hitch and connecting the retrofit wiring harness

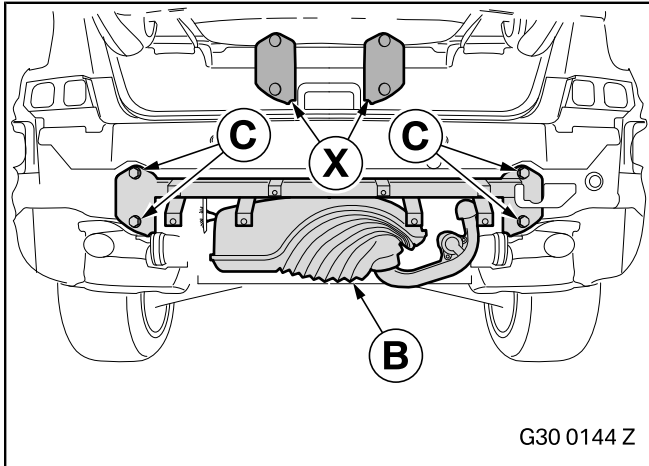

▶ Note the tightening torque value: 108 Nm. ◀

Place the seal **X** between the car and the trailer tow hitch **B** before installation.

Bolt trailer tow hitch **B** into place using hexagon nuts **C**.

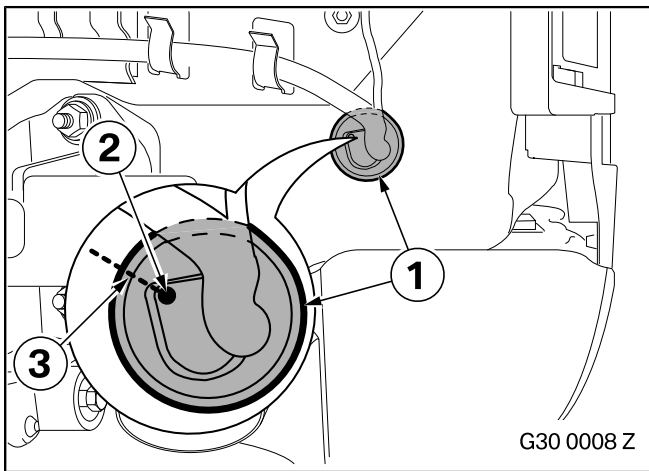

⚠ When drilling, make sure that no cables behind drilling point are damaged. ◀

Remove the rubber grommet (1).

Drill a hole in the rubber grommet (1) on the embossed mark (2) with a 10 mm drill bit.

Cut the rubber grommet (1) at the cutting point (3).

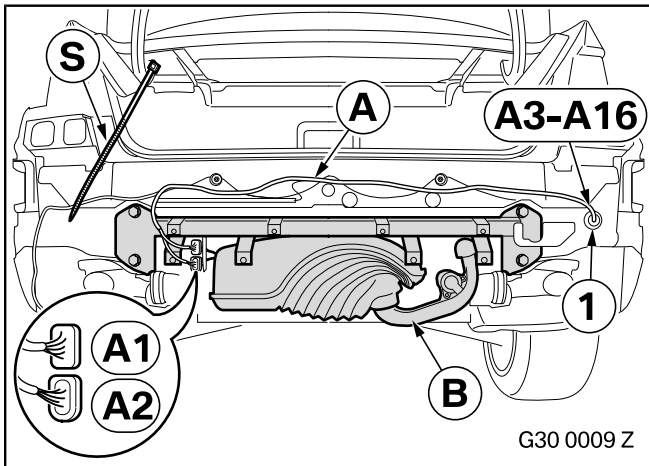

Connect branches **A1-A2** of the retrofit wiring harness to trailer tow hitch **B**.

Route retrofit wiring harness **A** to the right-hand side of the car.

Route branches **A3-A16** through the cut rubber grommet (1) into the interior of the car.

Seal the rubber grommet (1) and insert it in the opening so that it is watertight.

Secure retrofit wiring harness **A** using cable ties **S** to the standard vehicle wiring harness.

## 8. Installing the trailer tow hitch and connecting the retrofit wiring harness

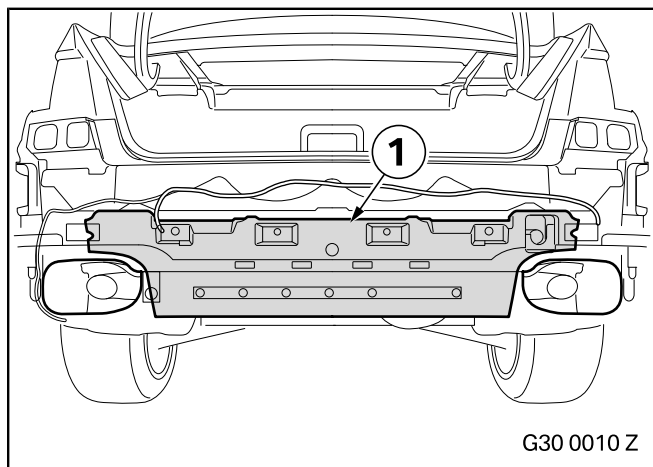

Attach the holder (1).

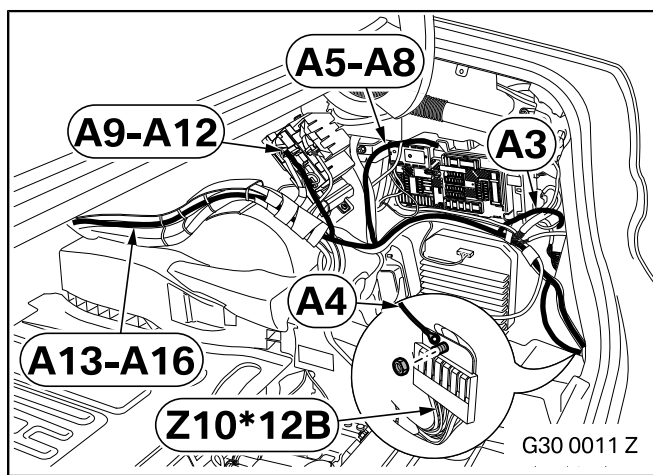

Route branches **A3-A16** as follows:

- Branch **A3** to the trailer tow hitch button installation point
- Branch **A4** to ground support point **Z10\*12B** and screw it into position there
- Branches **A5-A8** to the installation point of the rear right fuse box
- Branches **A9-A12** to the installation point of the AAG control unit
- Branches **A13-A14** to the installation point of the BDC
- Branches **A15-A16** to the bus interface on right-hand A-pillar **R2**

## 8. Installing the trailer tow hitch and connecting the retrofit wiring harness

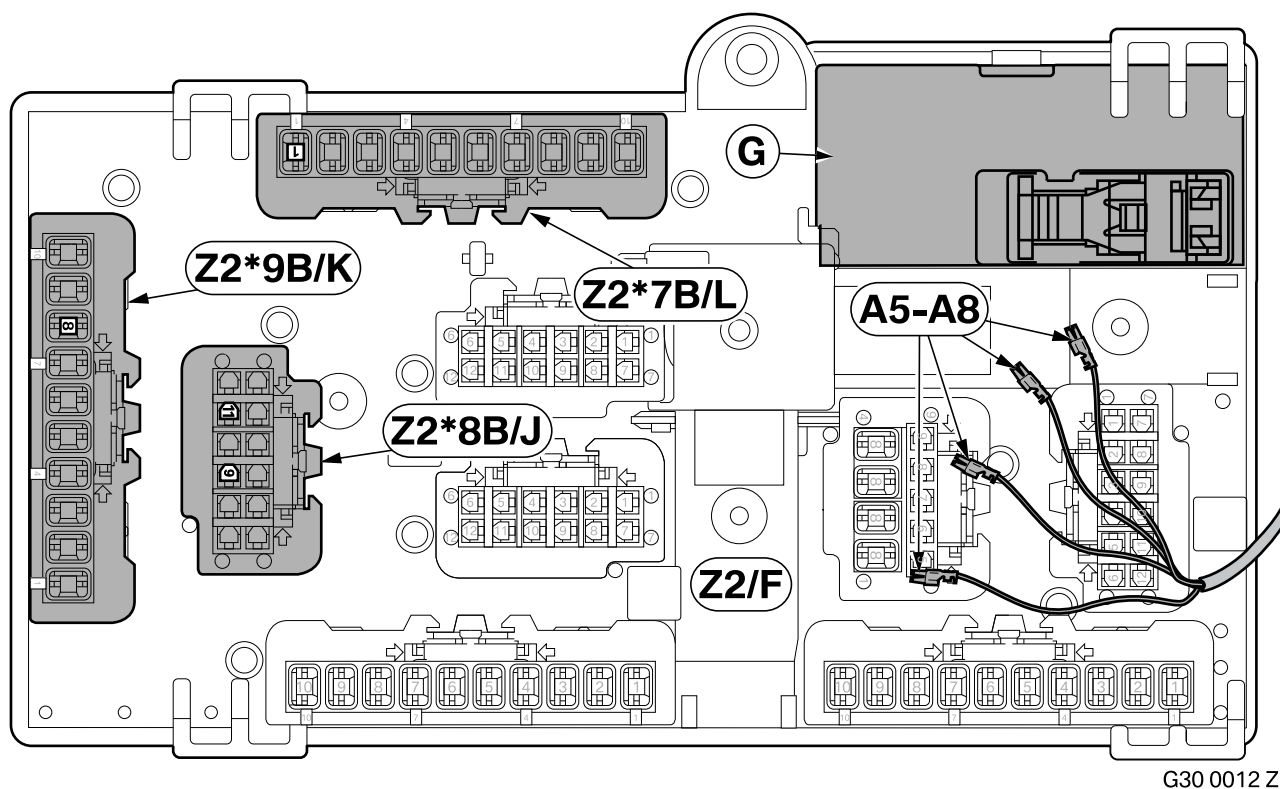

☐ If factory-installed rear fuse box **Z2** does not contain plugs **Z2\*8B** and **Z2\*9B**, rear fuse box **F** must be installed.

If socket housings **Z2\*7B**, **Z2\*8B** or **Z2\*9B** are not present, use socket housing **J**, **K** and **L**. ◀

Connect branches **A5-A8** to rear right fuse box **Z2** as follows:

- Branch **A5**, RT/GE cable, to PIN 11 of plug **Z2\*8B**, GN 12-pin socket housing, on fuse box **Z2**
- Branch **A6**, RT/SW cable, to PIN 9 of plug **Z2\*8B**, GN 12-pin socket housing, on fuse box **Z2**
- Branch **A7**, RT/BR cable, to PIN 8 of plug **Z2\*9B**, VI 10-pin socket housing, on fuse box **Z2**
- Branch **A8**, RT/VI cable, to PIN 1 of plug **Z2\*7B**, GN 10-pin socket housing, on fuse box **Z2**

Clip LIN module **G** to rear right fuse box **Z2**.

## 8. Installing the trailer tow hitch and connecting the retrofit wiring harness

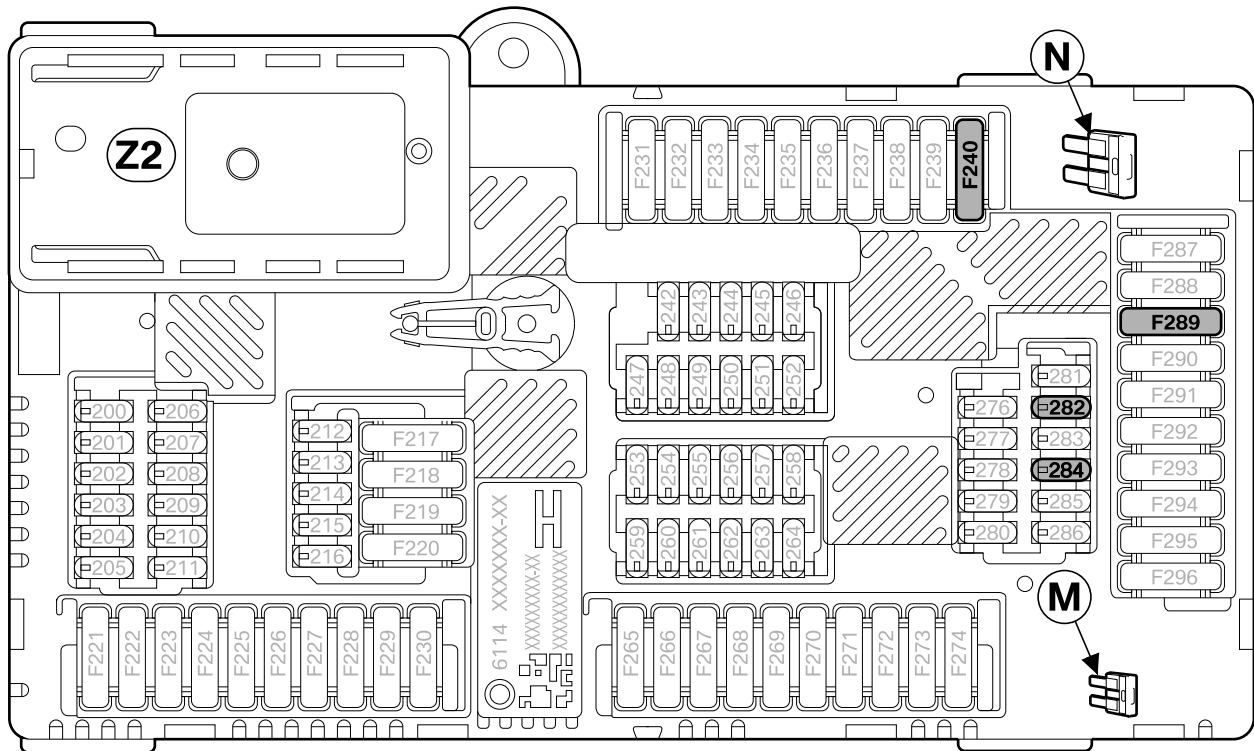

G30 0013 Z

Insert fuse **N** into slots **F240** and **F289** of fuse box **Z2**.

Insert fuse **M** into slots **F282** and **F284** of fuse box **Z2**.

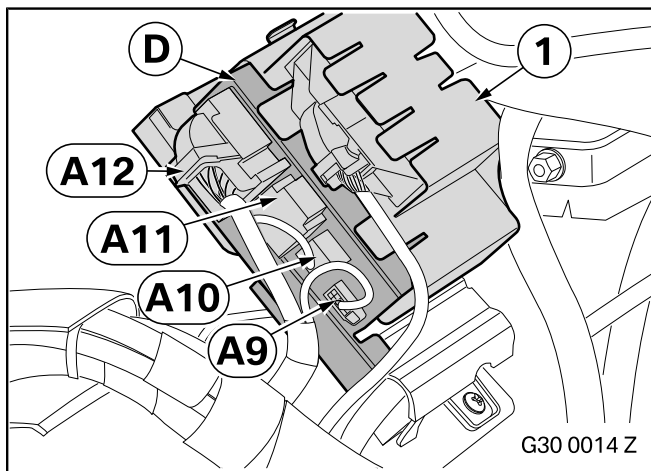

G30 0014 Z

Plug AAG control unit **D** into the control unit holder (1).

Connect branches **A9-A12** to control unit AAG **D**.

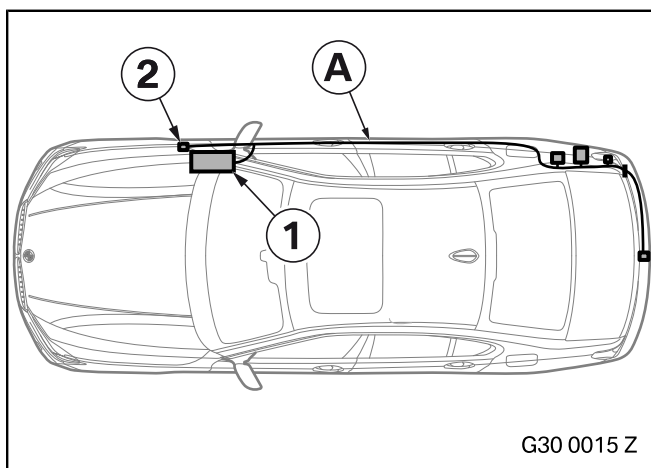

G30 0015 Z

## 8. Installing the trailer tow hitch and connecting the retrofit wiring harness

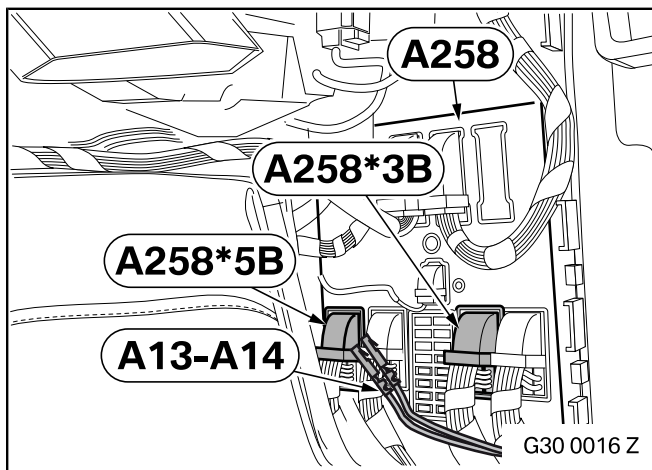

Connect branches **A13-A14** to BDC control unit **A258** as follows:

- Branch **A13**, SW cable, to PIN 32 of plug **A258\*5B** GR
- Branch **A14**, BL/GE cable, to PIN 37 of plug **A258\*3B** SW

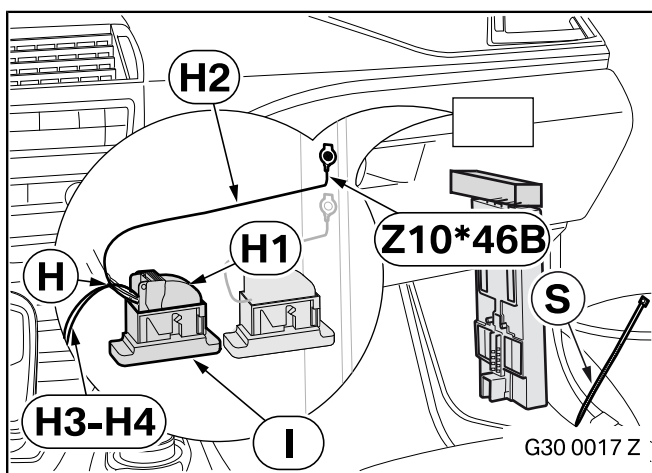

### Cars without bus interface R2 already installed

Connect retrofit wiring harness **H** as follows:

- Connect branch **H1**, SW 26-pin socket housing, to bus interface **I**
- Screw branch **H2**, ring eyelet, to ground support point **Z10\*46B**
- Route branches **H3-H4** to BDC installation point **A258**
- Secure bus interface **I** using cable ties **S** to the standard wiring harness near the A pillar

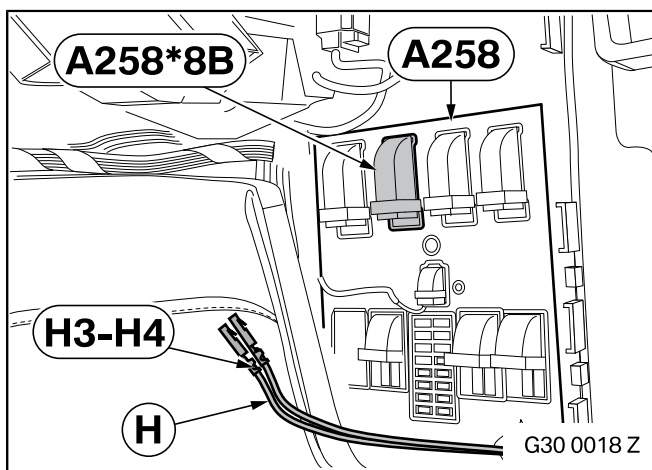

⚠ If PIN 49 and PIN 50 on plug **A258\*8B** of the BDC **A258** are occupied, connect branches **H3-H4** using 2-way miniature connectors **R** to the cables of the same colours. ◀

Connect branches **H3-H4** of retrofit wiring harness **H** as follows to plug **A258\*8B**, SW 54-pin socket housing of BDC **A258**:

- Branch **H3**, GE/BR cable, to PIN 50
- Branch **H4**, GE/RT cable, to PIN 49

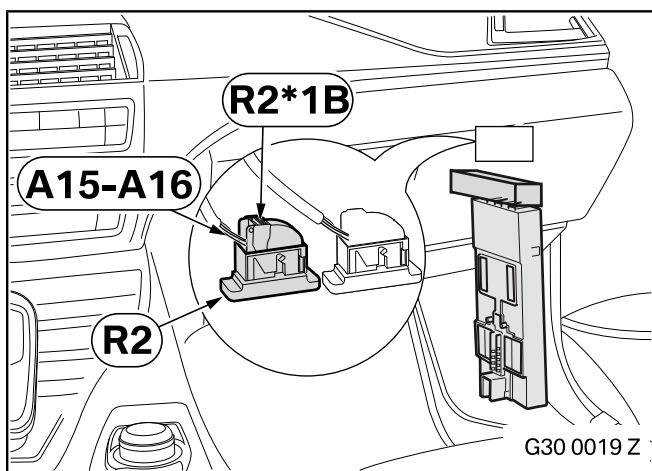

### For all cars

Connect branches **A15-A16** as follows to plug **R2\*1B** of bus interface **R2**, SW 26-pin socket housing:

- Branch **A15**, GE/BR cable, to PIN 5
- Branch **A16**, GE/RT cable, to PIN 18

## 8. Installing the trailer tow hitch and connecting the retrofit wiring harness

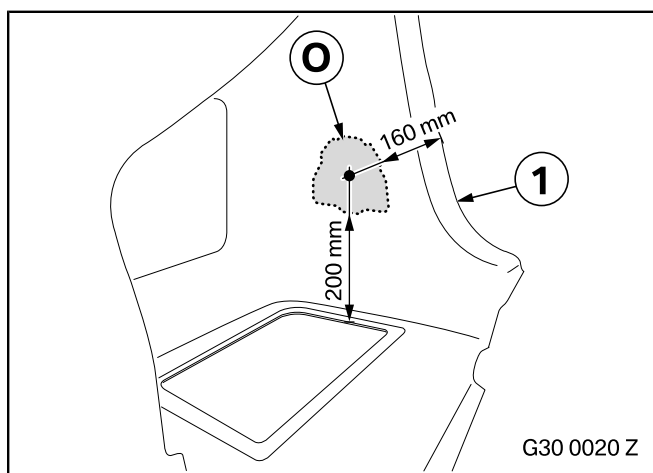

### G30 cars only

- When printing out template **O**, care must be taken to ensure that the pages are not scaled during printing. Once printed out, the scale shown on the template must be remeasured to check it. If the dimensions do not match, the template must be printed out again with the printer settings verified. ◀

Cut out template **O** at the end of these installation instructions.

Position template **O** on the right-hand luggage compartment wheel arch trim (1) as per the dimensions.

Using template **O** as a guide, mark and cut out the cutting area on the luggage compartment wheel arch trim (1).

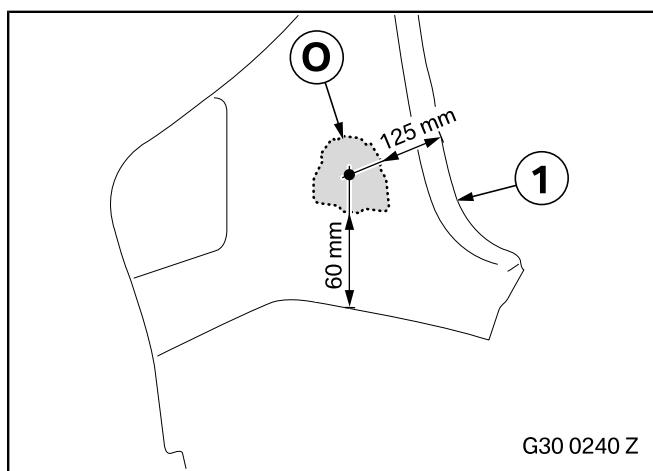

### G30 PHEV only

- When printing out template **O**, care must be taken to ensure that the pages are not scaled during printing. Once printed out, the scale shown on the template must be remeasured to check it. If the dimensions do not match, the template must be printed out again after adjusting the printer settings. ◀

Cut out template **O** at the end of these installation instructions.

Position template **O** on the right-hand luggage compartment wheel arch trim (1) as per the dimensions.

Using template **O** as a guide, mark and cut out the cutting area on the luggage compartment wheel arch trim (1).

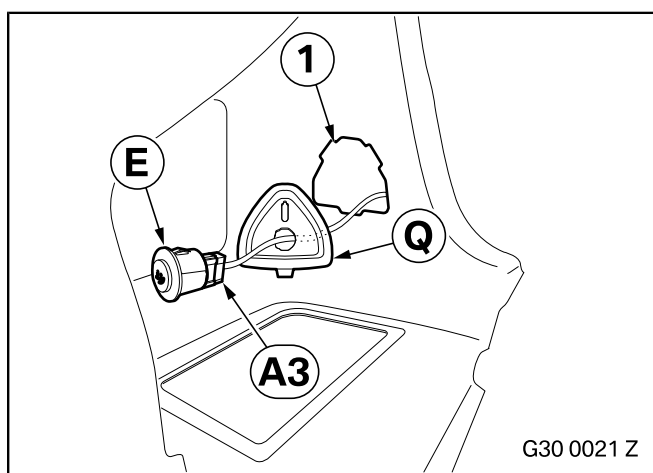

### For all cars

Connect branch **A3** through emergency unlocking mechanism finisher **Q** to trailer tow hitch button **E**.

Insert the trailer tow hitch button **E** with emergency unlocking mechanism finisher **Q** into the cut-out (1).

## 8. Installing the trailer tow hitch and connecting the retrofit wiring harness

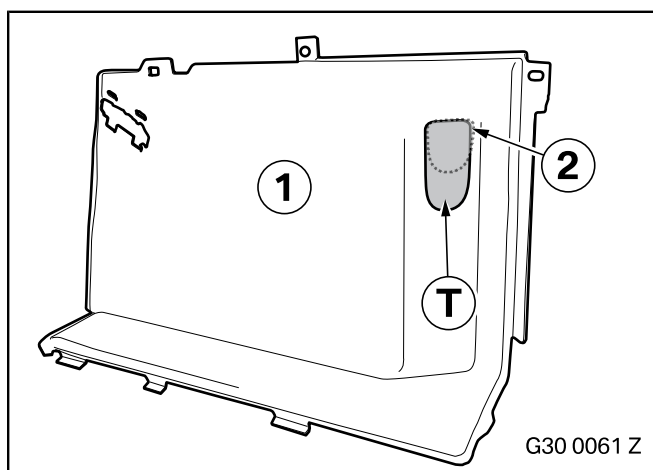

### G31, G32 only

When printing out template **T**, care must be taken to ensure that the pages are not scaled during printing. Once printed out, the scale shown on the template must be remeasured to check it. If the dimensions do not match, the template must be printed out again with the printer settings verified. ◀

Cut out template **T** at the end of these installation instructions.

Place template **T** on the right-hand luggage compartment trim (1) and align with the existing cutout.

Using template **T** as a guide, mark and cut out the cutting area on the luggage compartment trim (1).

Connect branch **A3** through emergency unlocking mechanism finisher **U** to trailer tow hitch button **E**.

Insert the trailer tow hitch button **E** with emergency unlocking mechanism finisher **U** into the cut-out (1).

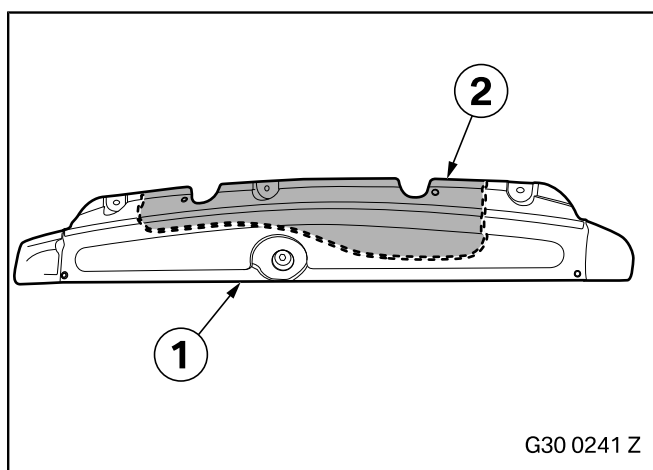
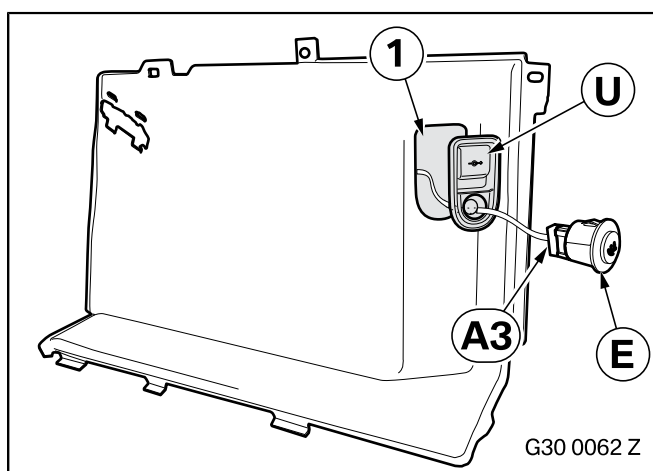

### G30 PHEV only

Cut out the cut-out (2) on the underbody panelling (1) in the pre-designated place.

## 8. Installing the trailer tow hitch and connecting the retrofit wiring harness

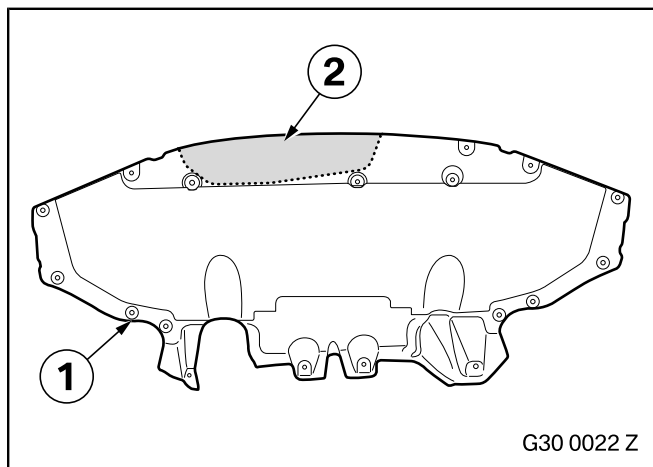

### For all cars

Cut out the cut-out (2) on the underbody panelling (1) in the pre-designated place.

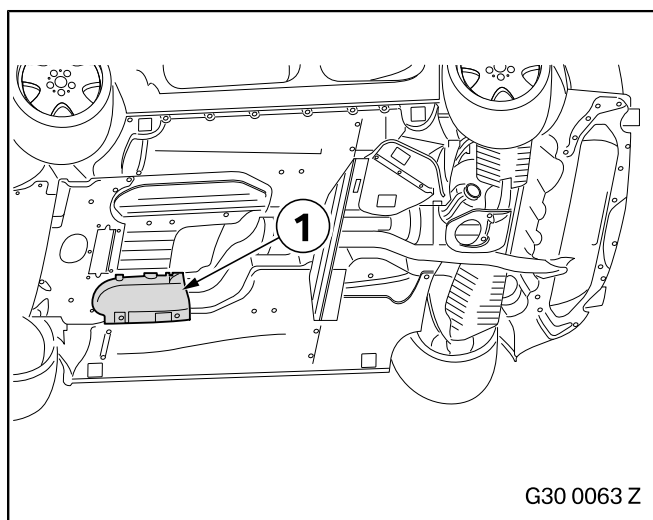

### G30, G31, F90 only

Remove the underfloor panel (1) (it is no longer required).

## 9. Replace underfloor positive battery cable (cars without SA 8SL only)

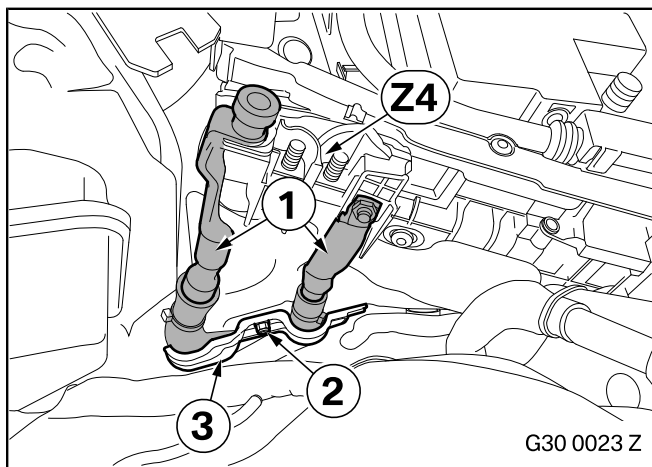

Disconnect the underfloor positive battery cable (1) as described in ISTA/AIR: 61 14 005 on the power distributor **Z4**.

Undo nut (2) and remove the holder (3).

Remove the underfloor positive battery cable (1) downwards.

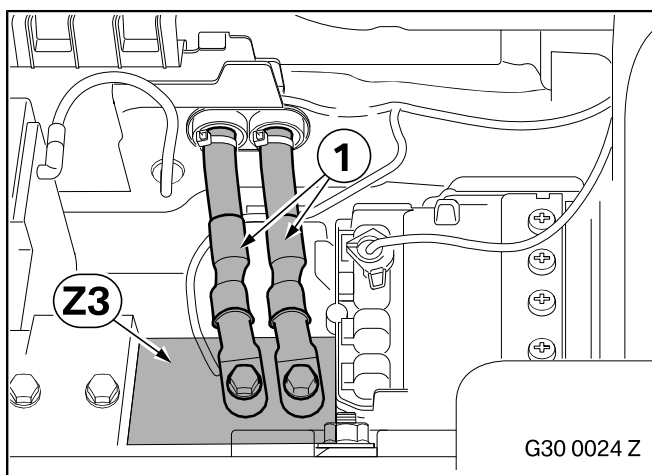

Disconnect the underfloor positive battery cable (1) as described in ISTA/AIR: 61 14 020 on the power distributor **Z3**.

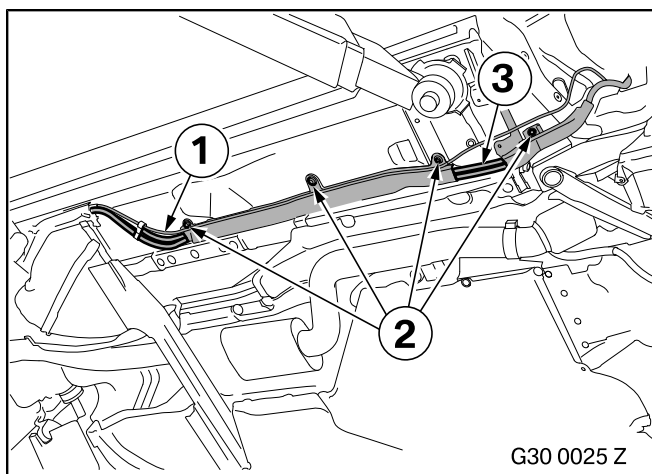

Release the cable (1) and place it to the side.

Undo the plastic nuts (2).

Unthread the underfloor positive battery cable (3) downwards.

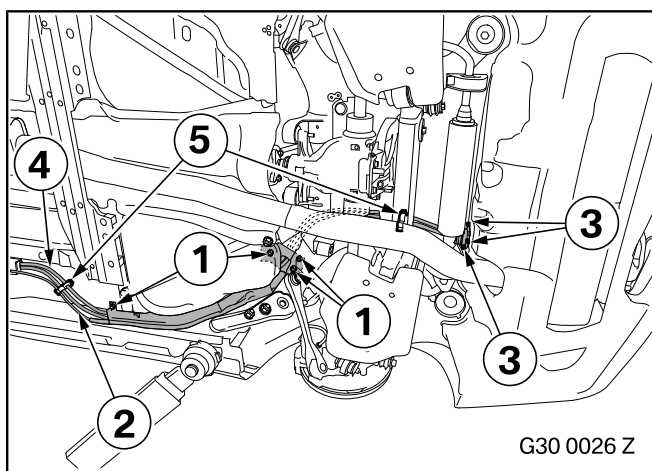

Undo the plastic nuts (1).

the cable (2) and place it to the side.

Undo the hexagonal nuts (3).

Unthread the underfloor positive battery cable (4) from the holders (5).

Remove the underfloor positive battery cable (4).

## 9. Replace underfloor positive battery cable (cars without SA 8SL only)

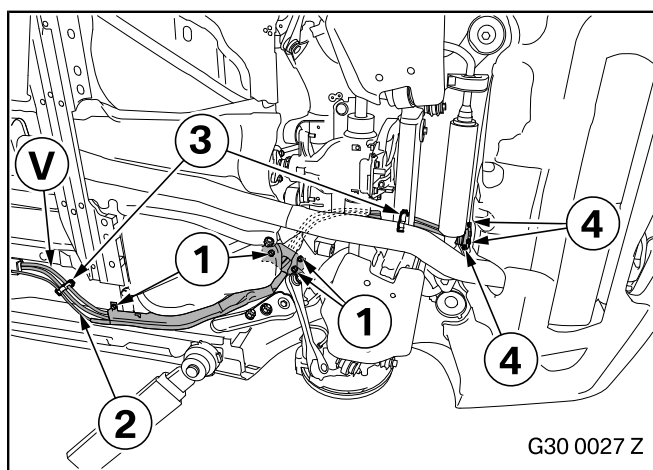

Thread in the underfloor positive battery cable **V**.

Tighten the plastic nuts (1).

Attach the cable (2).

Thread the underfloor positive battery cable **V** into the holders (4).

Tighten the hexagonal nuts (4).

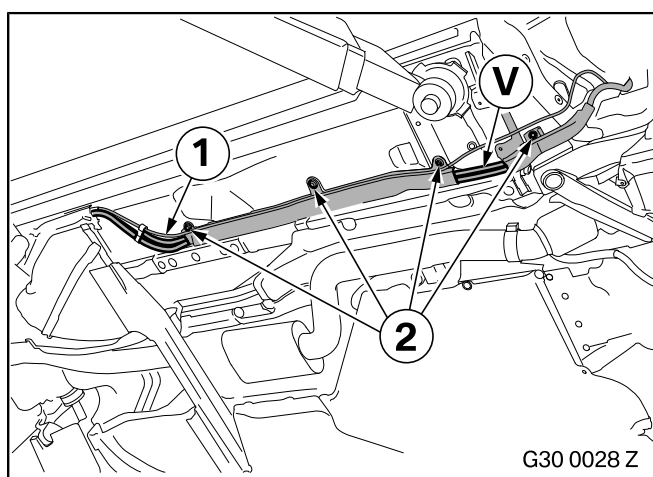

Thread in the underfloor positive battery cable **V** upwards.

Thread in the cable (1).

Tighten the plastic nuts (2).

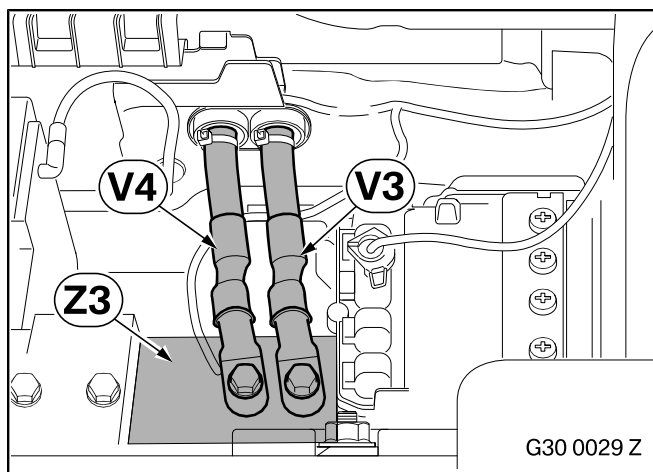

Secure branches **V3-V4** as described in ISTA/AIR: 61 14 020 to the power distributor **Z3**.

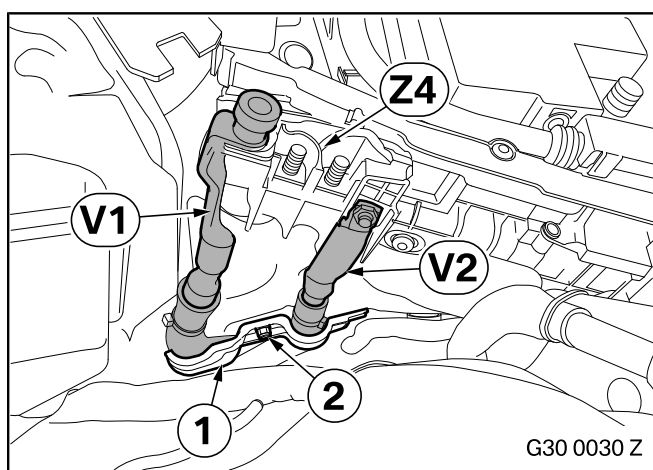

Secure branches **V1-V2** as described in ISTA/AIR: 61 14 005 to the power distributor **Z4**.

Secure the holder (1) with the nut (2).

## 10. Concluding work and coding

The retrofit system requires programming/coding.

- Connect the battery
- Connect the battery charger to the car
- Connect the car to the ISTA workshop system
- Open the ISTA car programming system
- When using ISTA, please refer to the instructions provided in the ISTA/P application documentation
- Select the "Electric pivot-mounted trailer tow hitch" retrofit via the – **Conversions** – path and work through the created action plan
- If necessary, carry out a vehicle test using the ISTA system, and note, or work through, any errors that has been recorded
- Conduct a function test
- Re-assemble the car

### **Perform the initialisation of the trailer tow hitch as follows:**

- Disconnect the trailer
- Disengage terminal 15
- Ensure the battery voltage is between 11 V and 14 V
- Open the tailgate
- Press and hold button **E** until the trailer tow hitch has performed a complete pivot in at least one direction without stopping

The initialisation is complete after one complete pivot-in and pivot-out operation and is indicated by a green, solid light on the LED of button **E**.

# 11. Wiring diagram

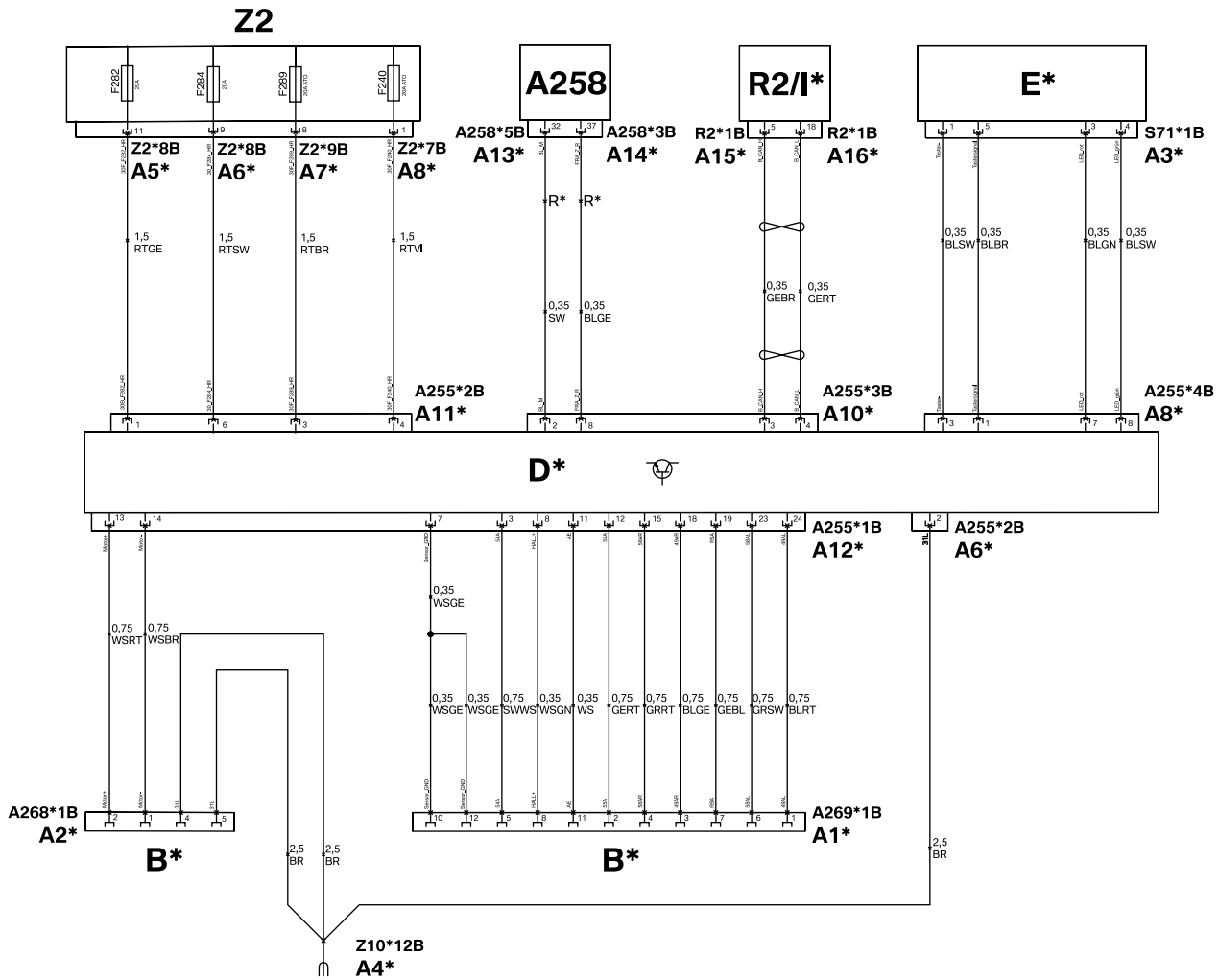

G30 0147 Z

## Legend

- A1\*** SW 12-pin socket housing, plug **X269\*1B**, to trailer tow hitch **B\***
- A2\*** SW 6-pin socket housing, plug **X268\*1B**, to trailer tow hitch **B\***
- A3\*** WS 6-pin socket housing, plug **S71\*1B**, to trailer tow hitch button **E\***
- A4\*** M6 ring eyelet, to ground connection **Z10\*12B**
- A5\*** Socket contact, to plug **Z2\*8B**, GN 12-pin socket housing of power distributor **Z2**
- A6\*** Socket contact, to plug **Z2\*8B**, GN 12-pin socket housing of power distributor **Z2**
- A7\*** Socket contact, to plug **Z2\*9B**, VI 10-pin socket housing of power distributor **Z2**
- A8\*** Socket contact, to plug **Z2\*7B**, GN 10-pin socket housing of power distributor **Z2**
- A9\*** GR 10-pin socket housing, plug **X255\*4B** to AAG control unit **D\***
- A10\*** SW 10-pin socket housing, plug **X255\*3B** to AAG control unit **D\***
- A11\*** SW 6-pin socket housing, plug **X255\*2B** to AAG control unit **D\***
- A12\*** SW 24-pin socket housing, plug **X255\*1B** to AAG control unit **D\***
- A13\*** Cable open, with miniature connector **R\*** to BDC plug **A258\*5B** GR
- A14\*** Cable open, with miniature connector **R\*** to BDC plug **A258\*3B** SW
- A15\*** Socket contact, to plug **R2\*1B**, SW socket housing, on bus interface **R2**
- A16\*** Socket contact, to plug **R2\*1B**, SW socket housing, on bus interface **R2**

# 11. Wiring diagram

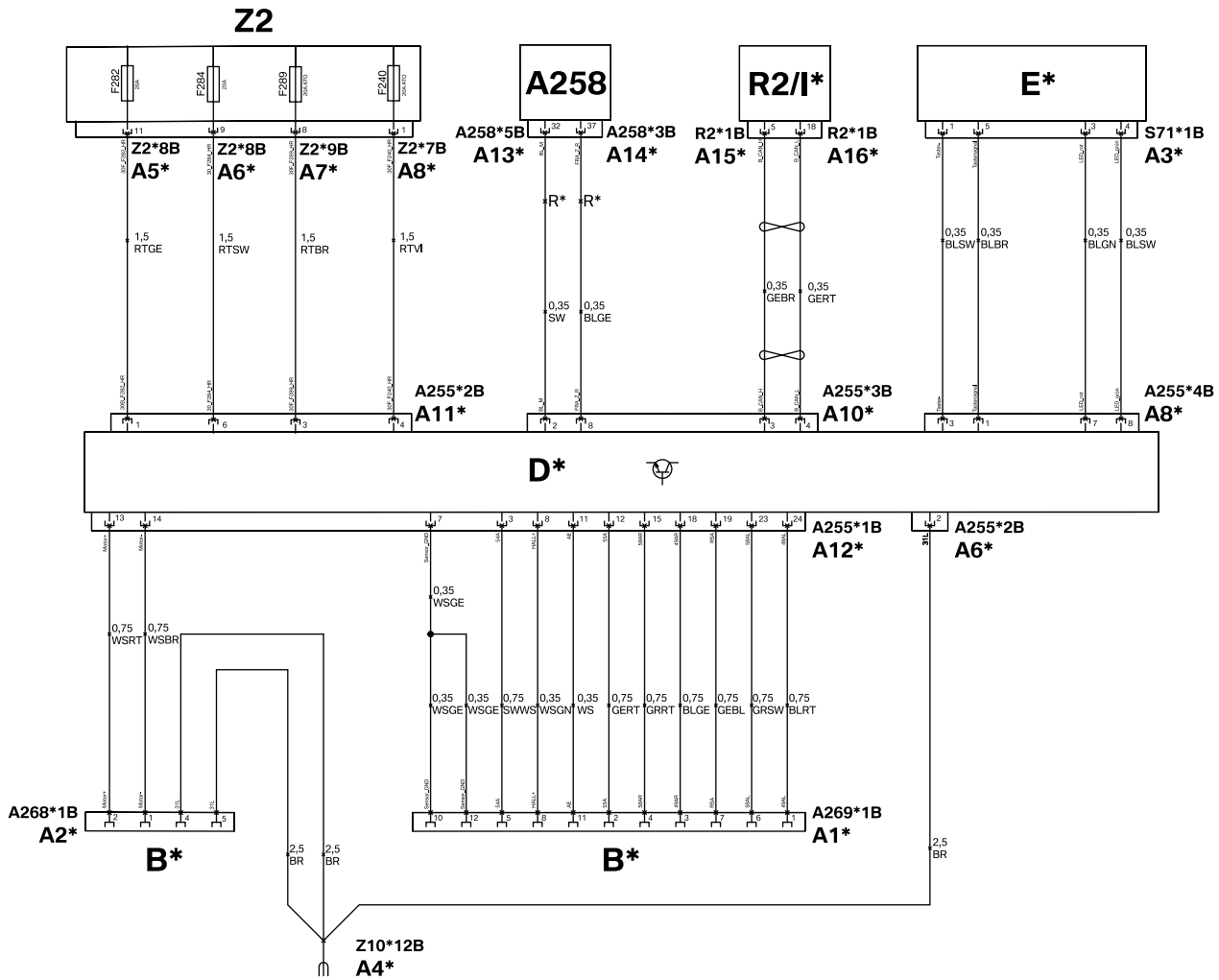

G30 0147 Z

- B\*** Trailer tow hitch
- D\*** AAG control unit
- E\*** Button
- I\*** Bus interface R2 (only for cars without bus interface **R2** already installed)
- R\*** Miniature connector

- A258** BDC control unit
- R2** Bus interface
- Z2** Rear right fuse box
- Z10\*12B** Rear right ground support point
- Z44** Front right fuse box

All of the designations marked with \* apply only to these installation instructions or this wiring diagram.



## Cable colours

BL	Blue	GR	Grey	RT	Red
BO	Bordeaux	L-GN	Light green	SW	Black
BR	Brown	NT	Natural	TR	Transparent
GE	Yellow	OR	Orange	VI	Violet
GN	Green	RO	Pink	WS	White

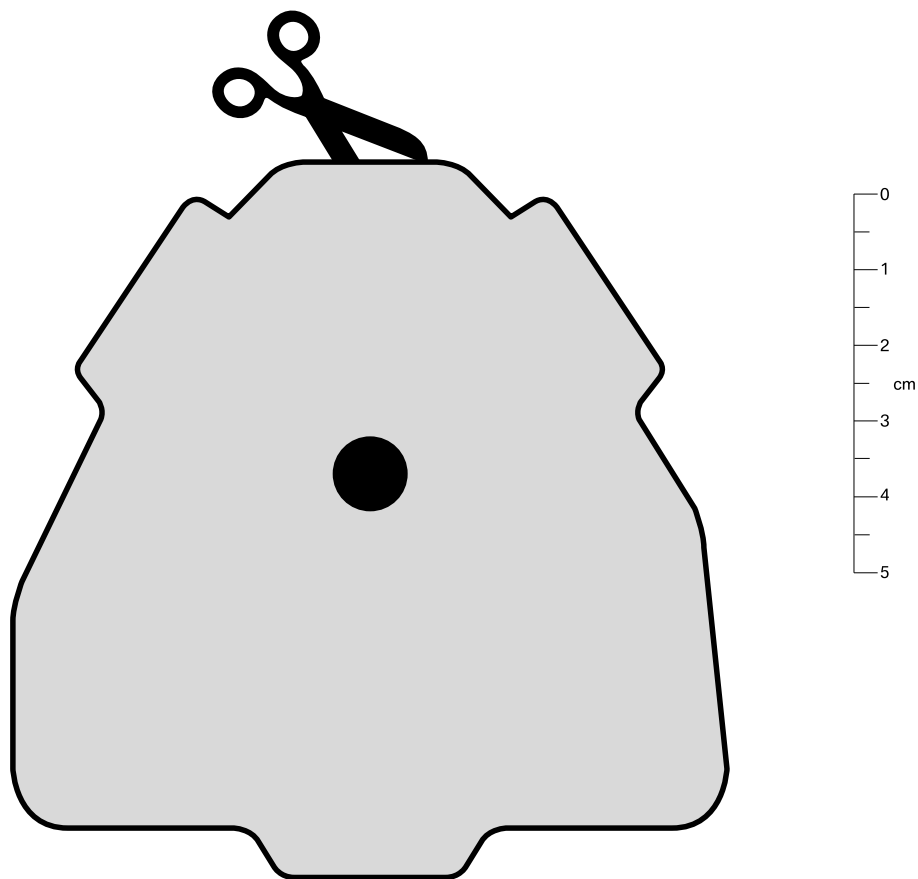
## 12. Template (G30, F90 only)



G11 0103 Z

 When printing out template , care must be taken to ensure that the pages are not scaled during printing. Once printed out, the scale shown on the template must be remeasured to check it. If the dimensions do not match, the template must be printed out again with the printer settings verified. 

Print out template  without fit to page.

### 13. Template (G31, G32 only)

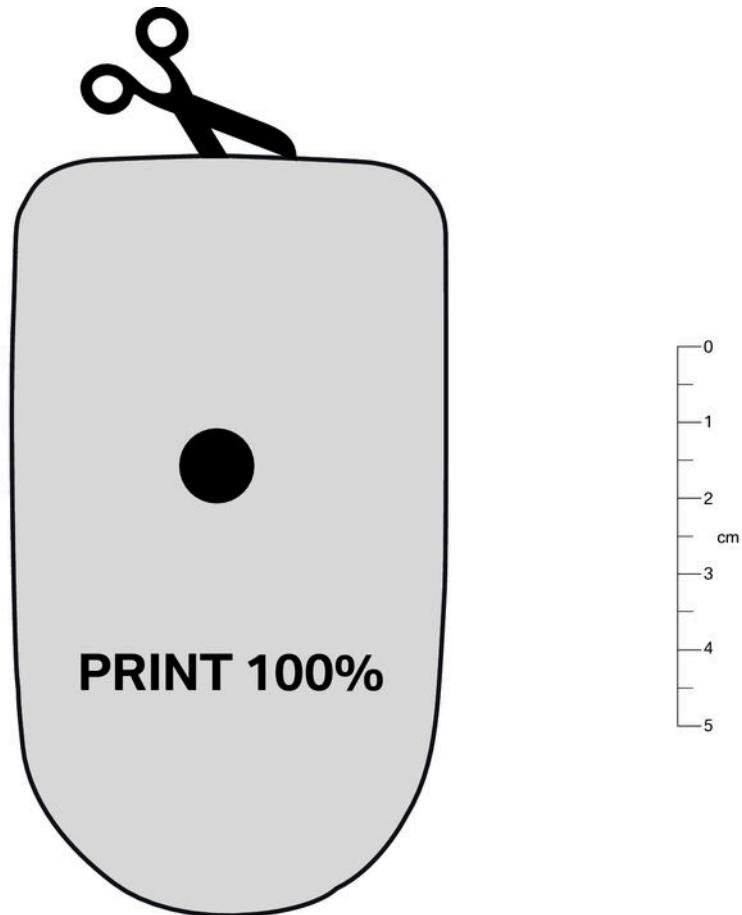

G30 0035 Z

- ▶ When printing out template **T**, care must be taken to ensure that the pages are not scaled during printing. Once printed out, the scale shown on the template must be remeasured to check it. If the dimensions do not match, the template must be printed out again with the printer settings verified. ◀

Print out template **T** without fit-to-page option.

## 14. Coupling ball clearances and installation height for towing ball coupling

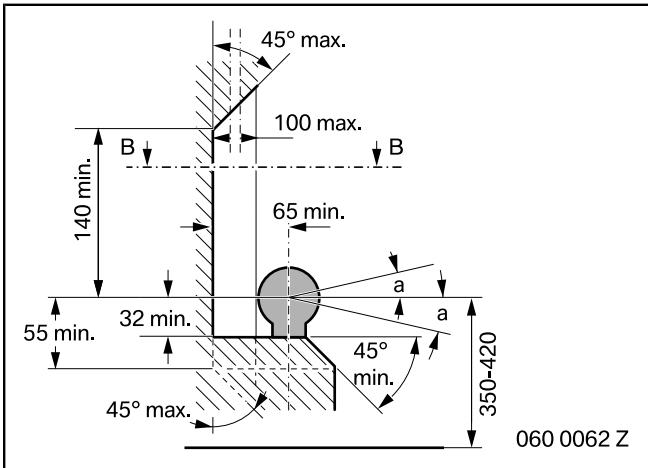

Space for coupling ball, side view.

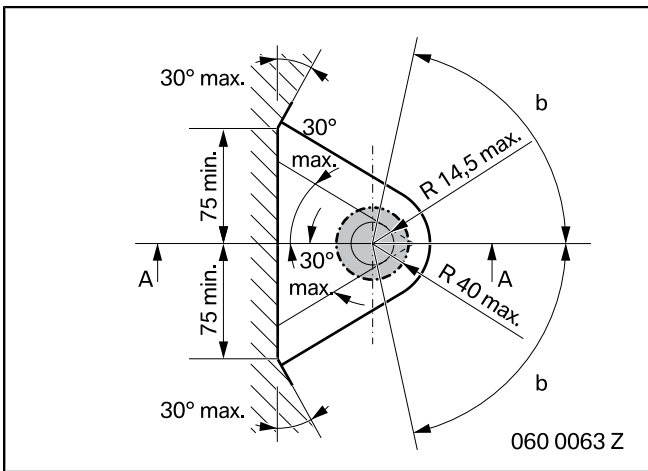

Space for coupling ball, plan view.

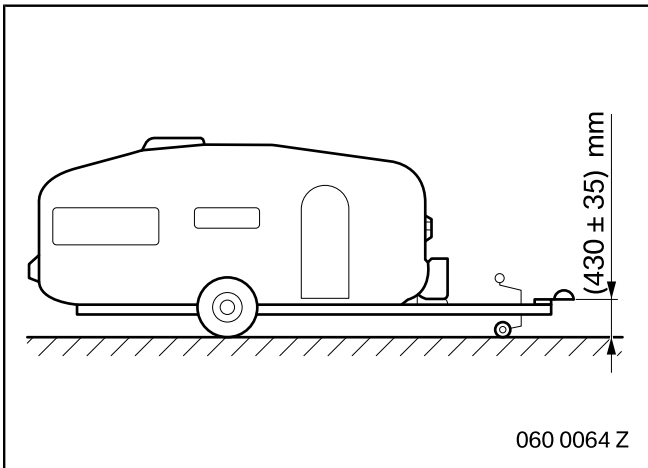

Installation height for the towing ball coupling.

## 15. Statutory regulations under ECE Directive R55

### Appendix VII

#### Regulations for the homologation of a vehicle for the optional installation of mechanical connection devices (trailer tow hitches)

##### 1. General regulations

###### 1.1

The vehicle manufacturer determines which types and classes of connecting devices can be fitted onto the vehicle type, and specifies the values D, V<sup>1</sup>, S or U (if applicable) which are based on the design of the vehicle type in combination with the planned type of connecting devices. The code values D, V, S or U of the connecting devices approved in accordance with this directive must be greater than or equal to those specified for the vehicle type in question.

###### 1.2

The connection devices must be installed on the vehicle type in accordance with the installation instructions specified by the vehicle manufacturer and in compliance with the manufacturer of the connection device and the Technical Service. The vehicle manufacturer defines the permitted points for securing the connection devices to the vehicle type and, if necessary, the mountings, installation plates, etc. that must be mounted on this specific vehicle type.

###### 1.3

Only automatic hitches may be used for hitching up trailers with a gross weight of more than 3.5 tonnes to motor vehicles; these automatic hitches must permit an automatic hitching procedure.

###### 1.4

When connecting devices of class B, D, E and H are fitted to trailers, it is always necessary to assume a value of 32 tonnes for the total mass T of the towing vehicle in order to calculate the D value. If the D value of the connecting device for T = 32 tonnes is not sufficient, the resultant restriction relating to the mass T of the towing vehicle and the mass of the vehicle combination (towing vehicle and trailer) must be specified in the approval sheet for the trailer.

<sup>1</sup> The V value must only be specified for vehicles with a maximum technical gross weight in excess of 3.5 tonnes.

## 15. Statutory regulations under ECE Directive R55

### 2. Special regulations

#### 2.1

Fitting coupling balls and towing brackets (ball head with coupling device)

##### 2.1.1

When coupling balls with holders are fitted to a vehicle type of class M1, class M2 below 3.5 tonnes or class N1, the clearance and height dimensions shown in figures **1** and **2** must be maintained. This requirement does not apply to off-road vehicles in the sense of Appendix II of Directive 92/53/EEC. Unspecified details are to be selected to suit the appropriate purpose. The dimensions and angles must be checked using suitable measuring instruments.

##### 2.1.2

The vehicle manufacturer must supply installation instructions for coupling balls and towing brackets. These installation instructions must specify whether the attachment area requires reinforcing.

##### 2.1.3

It must also be possible to couple and uncouple coupling heads when the longitudinal axis of the coupling head in relation to the centre line of the coupling ball and towing bracket

- a) is turned horizontally through  $b = 60^\circ$  to the right or left (see Figure **2**),
- b) is turned vertically through  $a = 10^\circ$  to the right or left (see Figure **1**),
- c) is rotated axially through  $10^\circ$  to the right or left.

##### 2.1.4

The mounted coupling ball must not obscure the rear registration plate or the space provided for the rear registration plate; otherwise, a ball that can be removed without requiring special tools must be used.

#### 2.2

Installing towing ball couplings

##### 2.2.1

Class B coupling heads may be used with trailers of a maximum gross weight of up to 3.5 tonnes. Towing ball couplings must be installed in such a way that the coupling point of the trailer (when the trailer is horizontal with less than the maximum axle load) is  $430 \text{ mm} \pm 35 \text{ mm}$  above the horizontal wheel contact level (see Figure 3). The horizontal position for caravans and trailers is the position at which the floor or the loading bed is horizontal. For trailers without a reference plane of this nature (for example boat trailers and the like), the manufacturer must specify a suitable reference line for defining the horizontal position. The required height only applies to trailers to be coupled to the cars listed in 2.1.1.

##### 2.2.2

It must be possible to operate coupling heads safely within the clearance of the coupling ball as shown in figures **1** and **2**.

## 15. Statutory regulations under ECE Directive R55

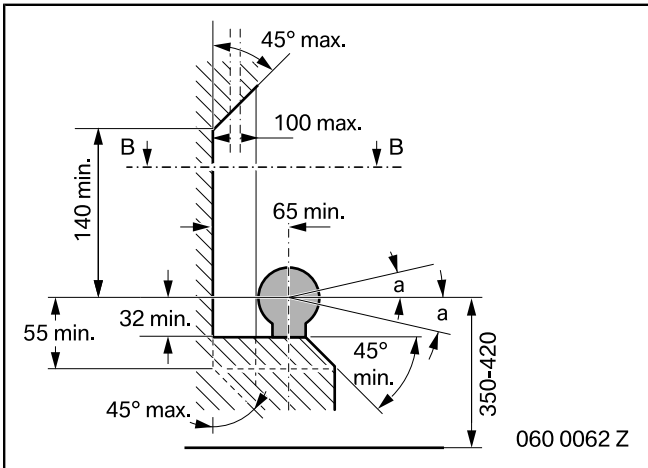

Figure 1

Space for coupling ball, side view.

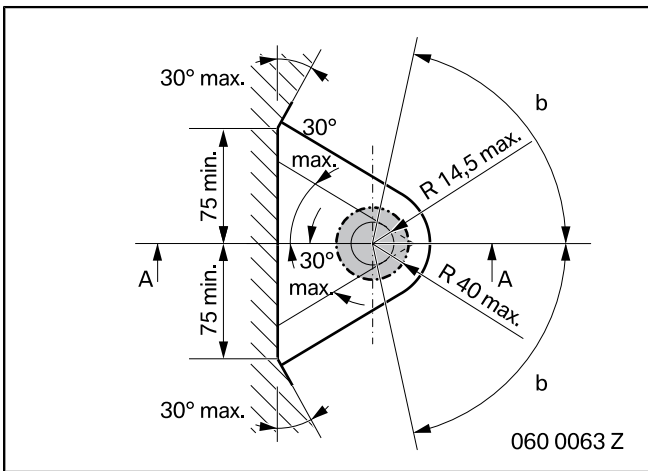

Figure 2

Space for coupling ball, plan view.

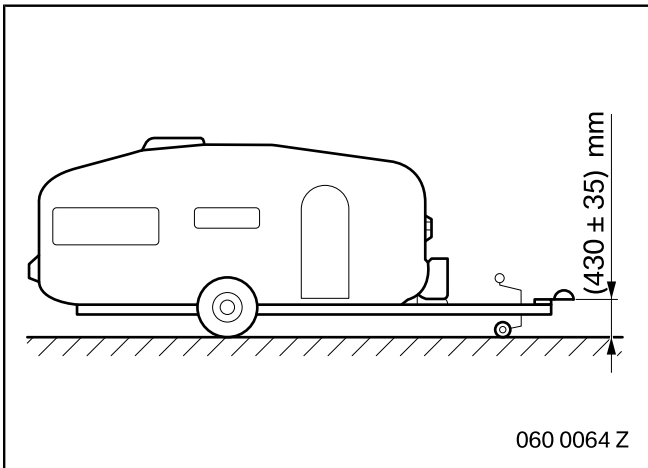

Figure 3

Installation height for the towing ball coupling.