

16 19 050 Removing and installing the passive tank SCR

PRELIMINARY WORK

1 – Remove right tank cover



Description is for left component only. Procedure on the right side is identical.

► Removing the tank cover



To provide a better overview: Schematic diagram with partially hidden components.



Description is for left component only. Procedure on the right side is identical.

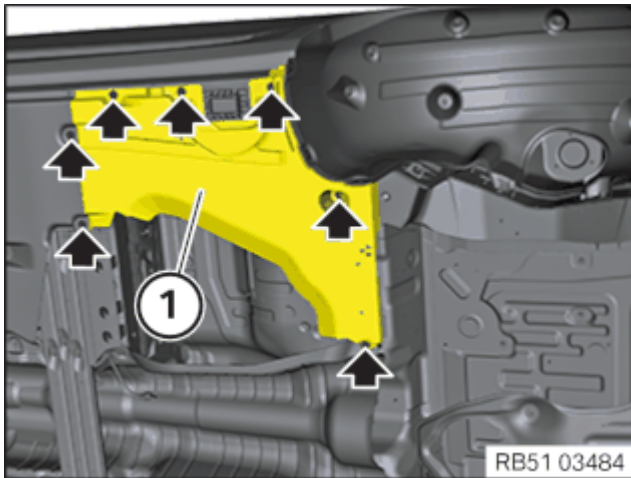

- Remove screws (arrows).
- Guide the tank cover (1) out.

2 – Draw off SCR tank (passive tank)



Materials harmful to health.

Contact with fluids harmful to health!

- Note and follow safety information on containers.
- Conduct all work with appropriate personal protective equipment only.



Use only lint-free cloths for cleaning the SCR system: WAYPALL cleaning cloths L20 - see BMW Group Parts.



After repair work, clean the working area thoroughly with water.

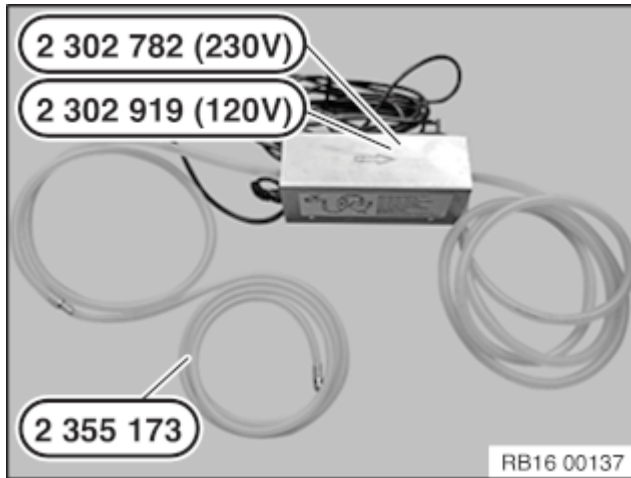

- Use extractor unit **2 302 782** (for 230V) or **2 302 919** (for 120V). Attach adaptor hose **2 355 173** to the intake side of the extractor unit.



Before starting up the AdBlue extractor unit: Comply with the manufacturer's operating instructions and safety regulations.

- Observe the extraction direction (see arrow on the extractor unit).

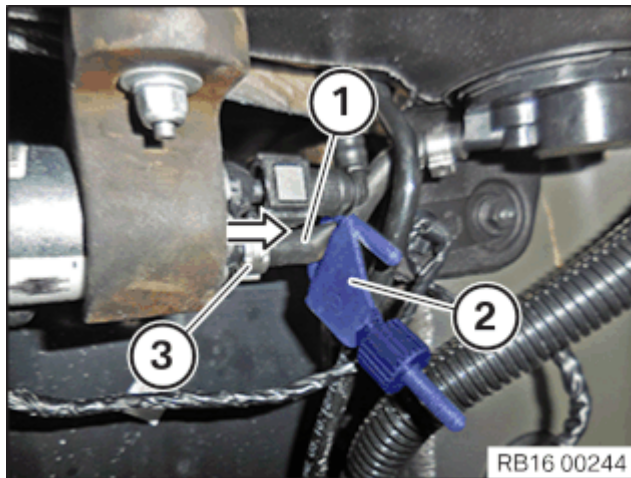

- Clamp off the hose between the passive tank and the transfer pump (1) using the hose clip (2).
- Release the hose clamp (3) and pull off the hose (1) from the transfer pump.

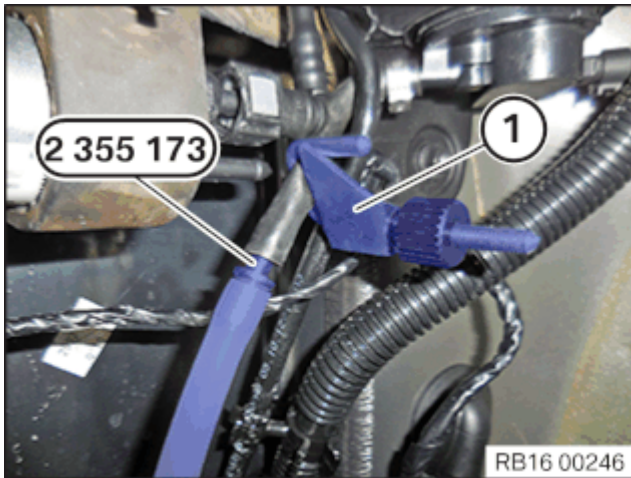

- Connect adapter hose **2 355 173** of extractor unit on hose.
- Remove hose clip (1).



Do not reuse the drawn off AdBlue.

- Extract AdBlue.

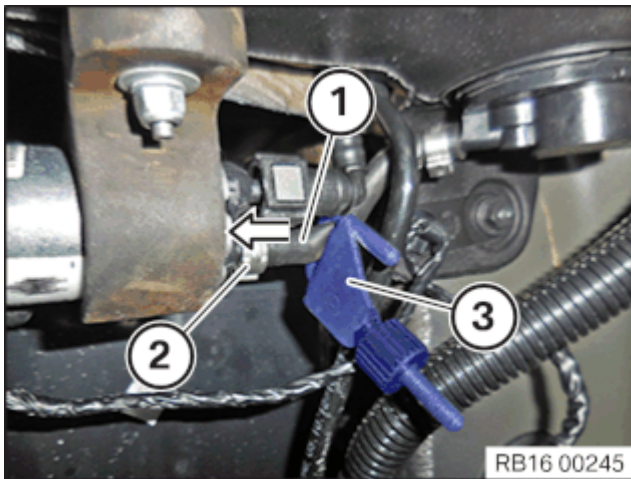

- Seal off the adapter hose **2 355 173** of the extractor unit.
- Mount the hose (1).
- Renew the hose clamp (2).
- Secure hose clamp (2).

3 – Removing the rear right wheel

► Removing the wheel



A wheel lift is recommended for easier wheel removal and installation without exertion (see Retailer Equipment Catalogue).

- **In vehicles with carbon ceramic brake: The wheel lift must be used to remove the wheel.** This process is intended to prevent damage to the brake disc.



- If several wheels are removed at the same time: Use a piece of chalk to mark on each tyre the axle and side on which the corresponding wheel is fitted.
- Loosen the wheel bolts (arrows) crosswise and remove the wheel.
- To loosen and tighten wheel bolts with a security code: Use the correct adapter from the set of special tools .

4 – Removing rear wheel arch cover



To provide a better overview: Schematic diagram with partially hidden components.

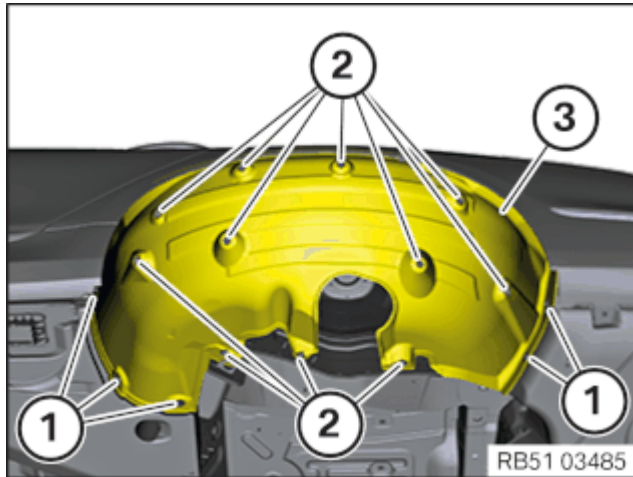

- Loosen screws (1).
- Loosen nuts (2).
- Guide the wheel arch cover (3) out.

MAIN WORK

5 – Remove the SCR tank (passive tank)

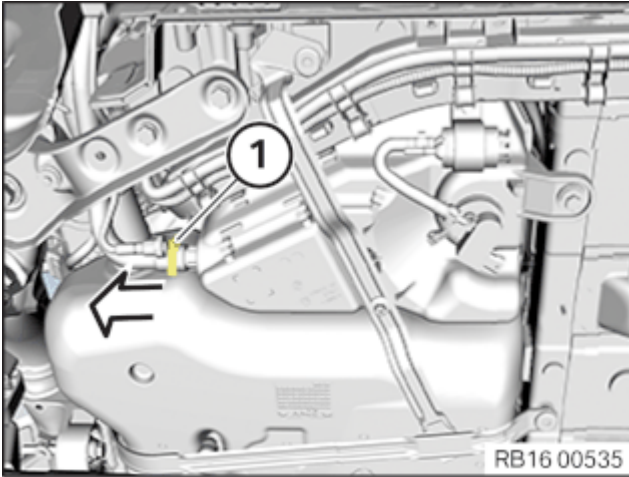

- Loosen the hose clamp (1) and remove the filling hose in the direction of the arrow.

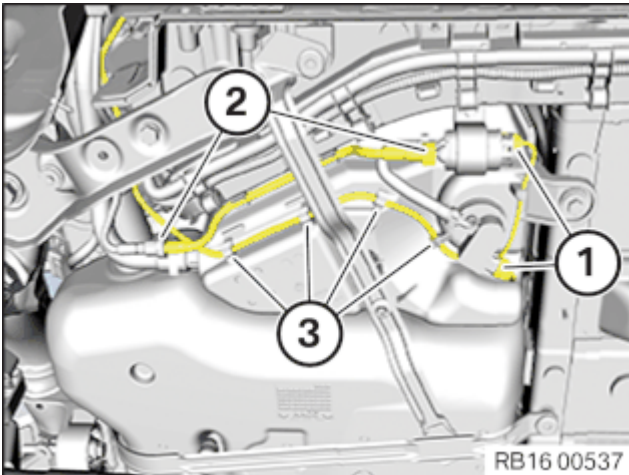

- Disconnect plug connection (1).
- Unlock and disconnect the snap fasteners (2).
- Detach cable from brackets (3).

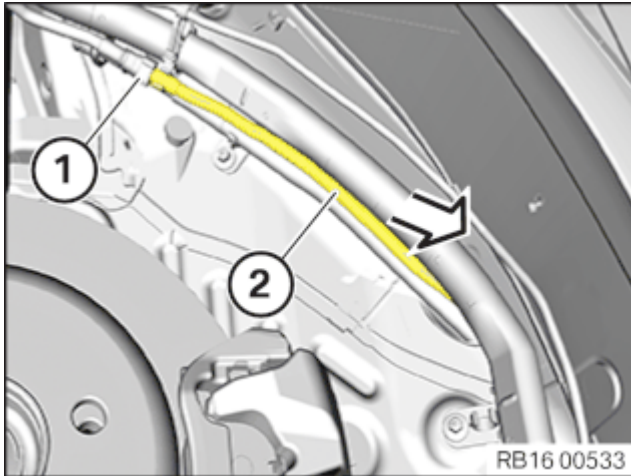

- Unlock and disconnect snap fastener (1).
- Guide the fuel filler neck breather pipe (2) through the body.

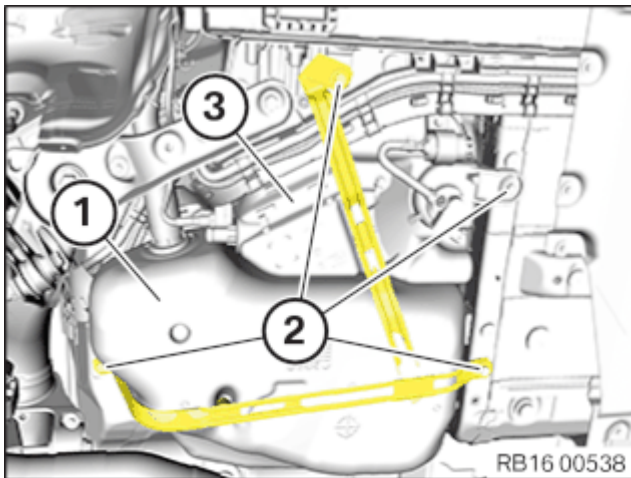

- The fuel tank (1) must be heavily supported.
- Unscrew the bolts (2) and remove the retaining strap of the passive tank.
- Guide out passive tank (3) in downward direction. Make sure that the fuel filler neck breather pipe is thereby routed through the body as well.

6 – Install the SCR tank (passive tank)

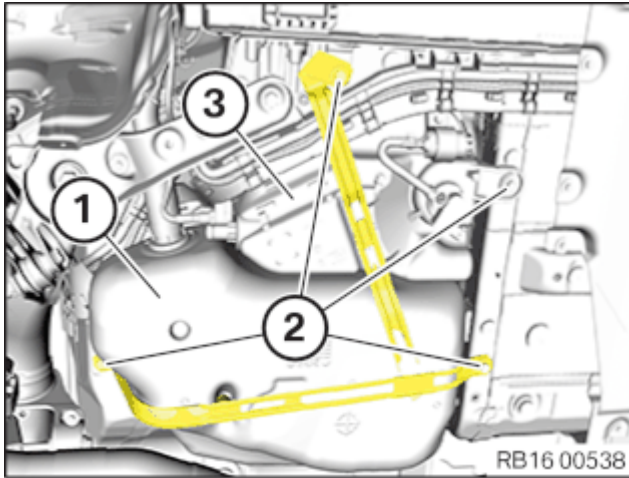

- Position SCR reservoir (3).
 - Guide the fuel filler neck breather pipe through the body into the wheel arch.
 - Mount the retaining strap of the passive tank.
 - Renew screws (2).
- Parts:** Screws
- Insert screws (2) and tighten.

Fuel tank retaining strap to body

M8 screw	Renew screws.	Tightening torque	19 Nm
----------	---------------	-------------------	-------

SCR passive tank to body

M8 screw	Renew screws.	Tightening torque	19 Nm
----------	---------------	-------------------	-------

- Remove the support below the fuel tank (1).
- Position the fuel filler neck breather pipe (2).
- Position snap fastener (1) and lock.

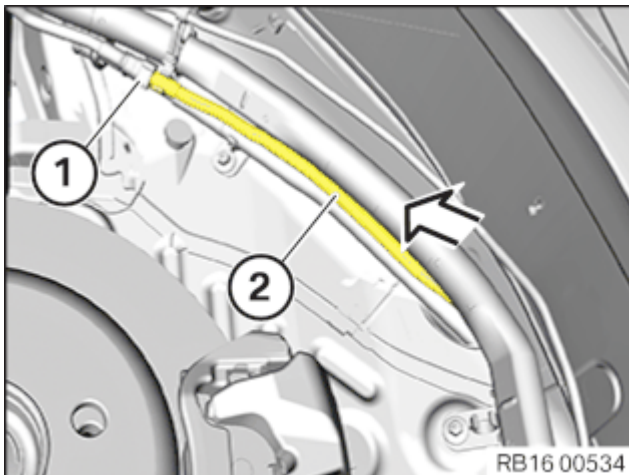

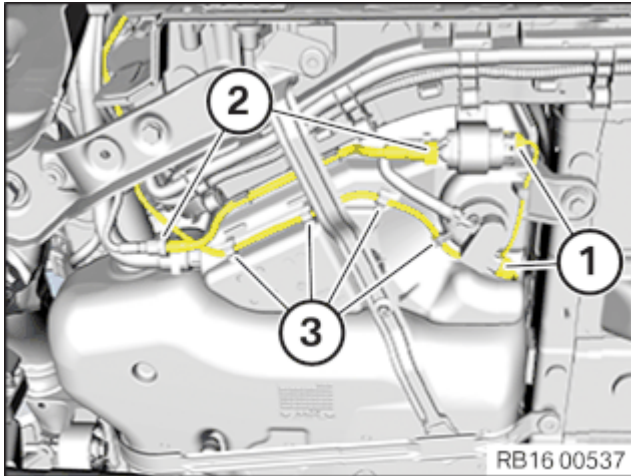

- Attach the cable to the brackets (3).
- Position and lock snap fasteners (2).
- Position and lock the plug connections (1).

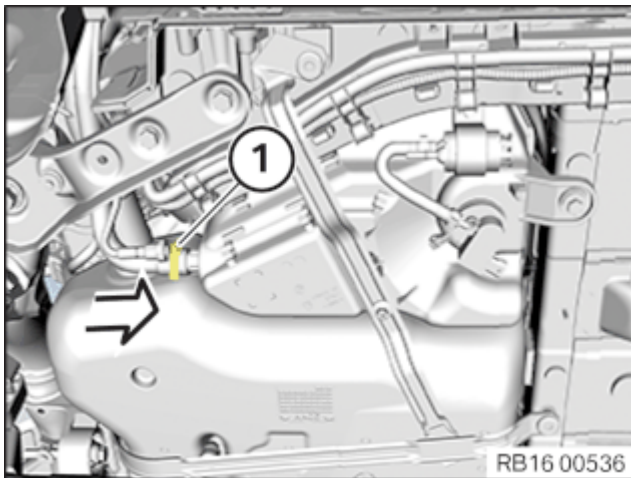

- Renew the hose clamp (1).
- Parts:** Hose clamp
- Install filling hose in the direction of the arrow.
 - Position hose clamp (1) and tighten.

Filling hose SCR reservoir

Hose clamp	Replace hose clamp.	Tightening torque	3.5 Nm
------------	---------------------	-------------------	--------

POSTPROCESSES

7 – Removing the rear wheel arch cover



To provide a better overview: Schematic diagram with partially hidden components.

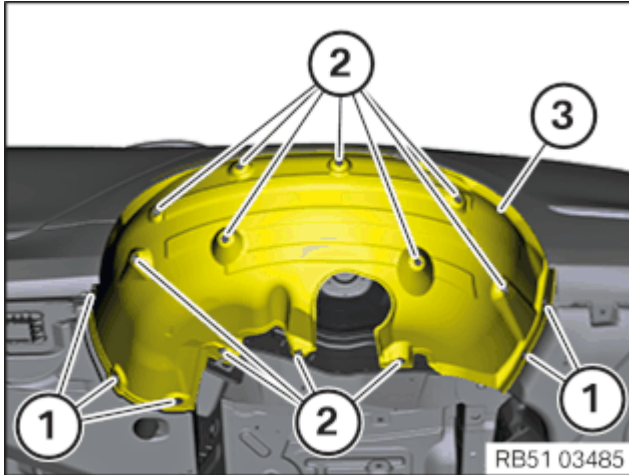

- Guide the wheel arch cover (3) in.
- Tighten the screws (1).
- Tighten nuts (2).

Wheel arch cover

Screw	3 Nm
Plastic nut	2.6 Nm

8 – Mounting the rear right wheel



Description is for left component only. Procedure on the right side is identical.

► Mounting the wheel

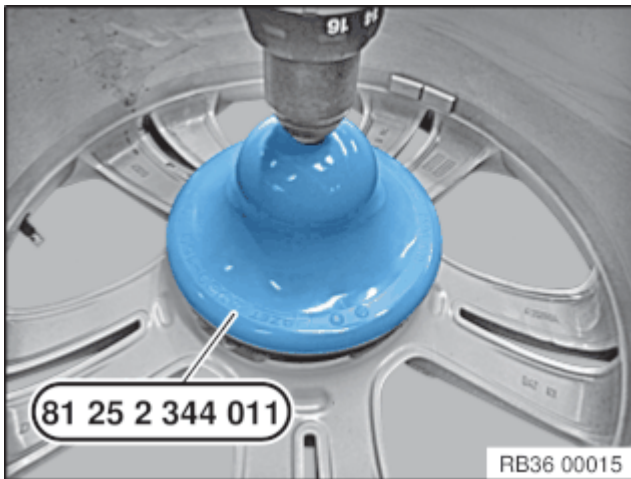
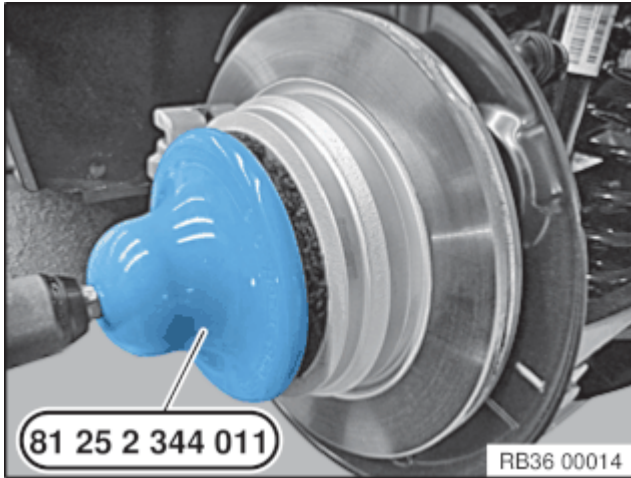

i

The contact surface between the brake disc and the wheel rim must be clean and free from oil and grease. There is otherwise a risk of the wheel becoming loose at a later time.

- Remove dirt, grease residues and corrosion from the contact surface with a drill and the special tool **2 344 011**.

Do not operate special tool **2 344 011** with an impact screwdriver.

- Degrease the contact surfaces with the universal cleaner (see BMW Group parts sales and distribution).
- In the event of grease residue in the area of the wheel bolt holes, remove and clean the brake disc.
- Remove dirt, grease residues and corrosion from the contact surface with a drill and the special tool **2 344 011**.

Do not operate special tool **2 344 011** with an impact screwdriver.

- Degrease the contact surfaces with the universal cleaner (see BMW Group parts sales and distribution).

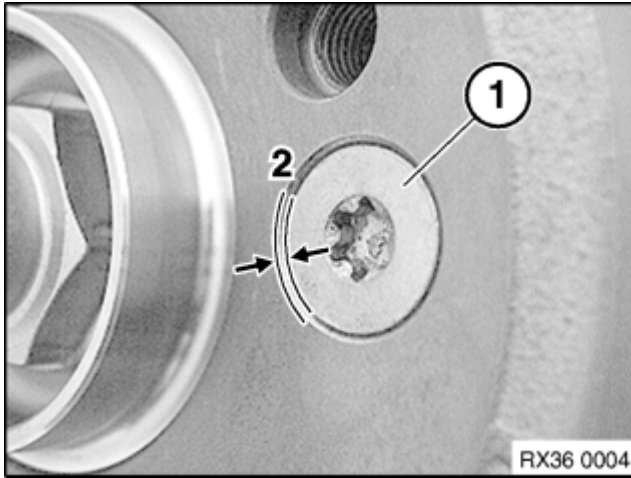

- Check that the mounting bolt (1) for the brake disc is securely fitted.

The mounting bolt (1) for the brake disc may **not** protrude on the contact surface (2) between the brake disc and the wheel rim.

Brake disc to front wheel hub

M8	Tightening torque	16 Nm
----	-------------------	-------

Brake disc to rear wheel hub

M8	Tightening torque	16 Nm
----	-------------------	-------

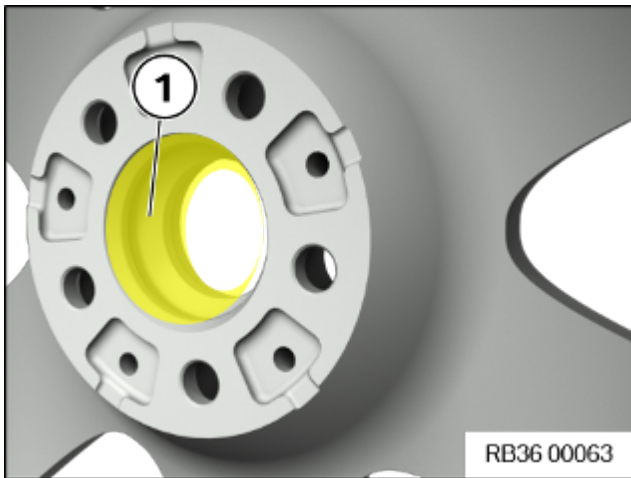

Wheel hubs and wheel centring on models G80, G81, G82, G83 and G87 must **not** be greased.

- Thinly grease the wheel centring (1) in the wheel rim.

Expendable materials

Brake pad paste	3 g, Bag	83192158851
* TU = Trade Unit. TU numbers cannot be ordered! For invoicing purposes only.	100 g, Tube	83192158852
	5 g, TU*	83230140233

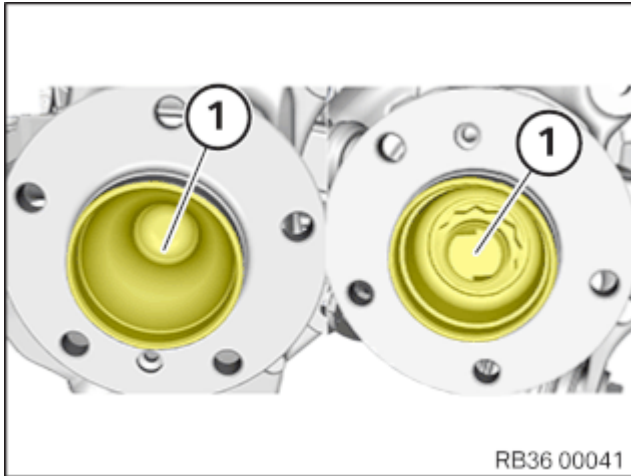

Wheel hubs and wheel centring on models G80, G81, G82, G83 and G87 must **not** be greased.

- Apply a thin layer of grease to the front and rear wheel hubs in area (1) to protect against corrosion.

Expendable materials

Brake pad paste	3 g,	83192158851
* TU = Trade Unit. TU numbers cannot be ordered! For invoicing purposes only.	Bag	
	100 g,	83192158852
	Tube	
	5 g,	83230140233
	TU*	



A wheel lift is recommended for easier wheel removal and installation without exertion (see Retailer Equipment Catalogue).

- **In vehicles with carbon ceramic brake: The wheel lift must be used to mount the wheel.** This process is intended to prevent damage to the brake disc.

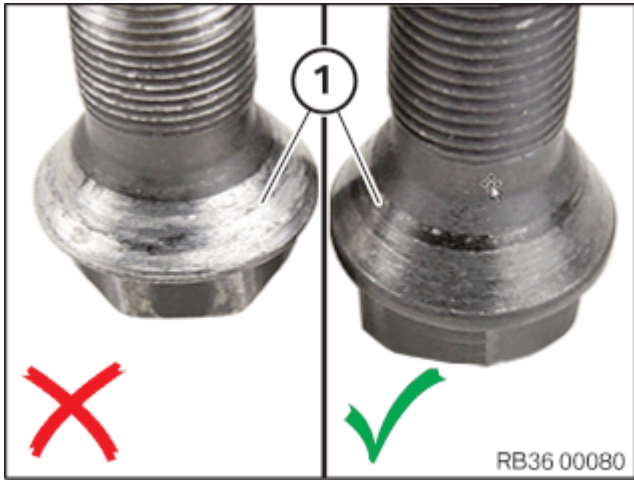

Check

- Check wheel bolts for wear.

Result

» Places (> 30%) of the bearing surface (1) of the taper on the screw head show a silver wear.

Measure

- Renew wheel bolts.



Never use impact screwdrivers or electric screwdrivers to screw in and tighten the wheel bolts.

The wheel rim must rest uniformly against the brake disc.

In the case of non-original BMW wheel bolts/wheel rims, it may be necessary to retighten the wheel bolts on account of setting properties (refer to the documentation from the manufacturer).

Do not apply oil to new wheel bolts.

Recutting a damaged thread (wheel bolt/wheel hub) is not permissible!

- Renew the corroded wheel bolts (arrows).
- Clean the wheel bolts (arrows).
- Check the wheel bolts (arrows) and threads for damage, renew the wheel bolts (arrows), if necessary.
- Position and tighten the wheel bolts (arrows).

Wheel bolts

M14/SW17	Screw in wheel bolts and evenly apply crosswise by hand to centre the wheel rim.	Tightening torque	140 Nm
	Tighten wheel bolts crosswise to the specified tightening torque with a calibrated torque wrench.	Check	140 Nm
	Check all wheel bolts in the same order or retighten to the specified		

9 – Filling SCR reservoir



Materials harmful to health.

Contact with fluids harmful to health!

- Note and follow safety information on containers.
- Conduct all work with appropriate personal protective equipment only.



Use only lint-free cloths for cleaning the SCR system: WAYPALL cleaning cloths L20 - see BMW Group Parts.



After repair work, clean the working area thoroughly with water.
Clean special tools with water after every use.



- Screw the special tool **2 302 783** with the flatter connection on the fluid tank with the AdBlue.
- Connect the other end of the special tool **2 302 783** to the filler neck of the SCR tank.
- Lift the fluid tank with the AdBlue over the fuel filler neck.
- Fill the SCR tank.
- If the SCR fluid tank is full before the fluid tank with the AdBlue is empty: Position the fluid tank down and unscrew the special tool **2 302 783**.
- Ensure that the AdBlue does not leak when unscrewing the special tool **2 302 783**.
- If necessary, immediately wash off any leaking AdBlue thoroughly with water.

10 – Putting the SCR tank system into operation



- Connect diagnosis and information system.
- Reset adaptations and adjustments in the SCR system.
- Carry out start-up of the SCR tank system.

Additional Information

Overview of Tightening Torques

Fuel tank retaining strap to body				Used in step 6
M8 screw	Renew screws.	Tightening torque	19 Nm	
SCR passive tank to body				Used in step 6
M8 screw	Renew screws.	Tightening torque	19 Nm	
Filling hose SCR reservoir				Used in step 6
Hose clamp	Replace hose clamp.	Tightening torque	3.5 Nm	
Wheel arch cover				Used in step 7
Screw			3 Nm	
Plastic nut			2.6 Nm	
Brake disc to front wheel hub				Used in step 8
M8		Tightening torque	16 Nm	
Brake disc to rear wheel hub				Used in step 8

Wheel bolts

Used in step **8**

M14/SW17	Screw in wheel bolts and evenly apply crosswise by hand to centre the wheel rim.	Tightening torque	140 Nm
	Tighten wheel bolts crosswise to the specified tightening torque with a calibrated torque wrench.	Check	140 Nm
	Check all wheel bolts in the same order or retighten to the specified tightening torque again.		

Overview of Special Tools

2 302 782 Pump



Common

Used in step [2](#)

Usage	AdBlue 230 exhaust pump for the extraction of the urea/water mixture(AdBlue®).
Included in the tool or work	
Storage location	Individual
Replaced by	
In connection with	Special tool 2355173
SI-Number	01 30 11 (767)

2 302 919 Pump



Common

Used in step [2](#)

Usage	AdBlue 110V exhaust pump for the extraction of the urea/water mixture(AdBlue®) from the vehicle-specific expansion tanks.
Included in the tool or work	
Storage location	Individual
Replaced by	
In connection with	Special tool 2355173
SI-Number	01 30 11 (767)

2 355 173 Hose

Used in step [2](#)

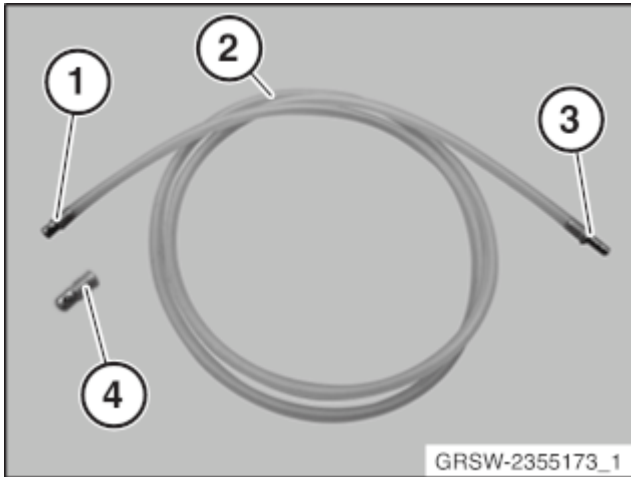

Common

Usage	Hose (hose extension) for AdBlue suction pump (81 39 2 302 782 or 81 39 2 302 919). This hose can be used to directly draw off AdBlue® from the “SCR“ active tank on the vehicle.
Included in the tool or work	
Storage location	Individual
Replaced by	
In connection with	WE 2302782
SI-Number	01 12 13 (964)

2 344 011 Tool



Common

Used in step [8](#)

Usage	Tool (hub cap grinder) for cleaning the attachment element of the wheel rim (wheel contact face) to the wheel hub.
Included in the tool or work	
Storage location	
Replaced by	
In connection with	
SI-Number	08 08 12 (872)

2 302 783 Hose

Used in step [9](#)



Common

Usage	Filler hose for non-drip filling of AdBlue in SCR vehicles (for all BMW models except E90 US version). (Disposable hose! Order new part in the case of wear!)
Included in the tool or work	
Storage location	Individual
Replaced by	
In connection with	
SI-Number	01 30 11 (767)

Replacement tools:

0 495 221 (36 1 323) Wheel bolt

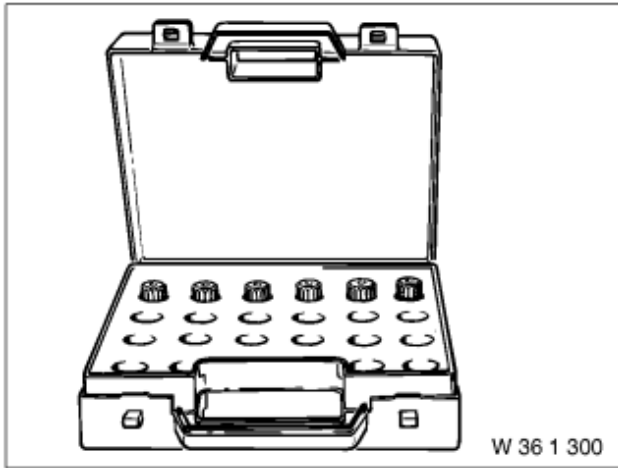

Common

Used in step [3](#)

Usage	(Code 30) Code 39 available separately, (see EPC) under 36 13 1 181 259
Included in the tool or work	0 492 518
Storage location	
Replaced by	
In connection with	
SI-Number	

0 495 224 (36 1 326) Wheel bolt

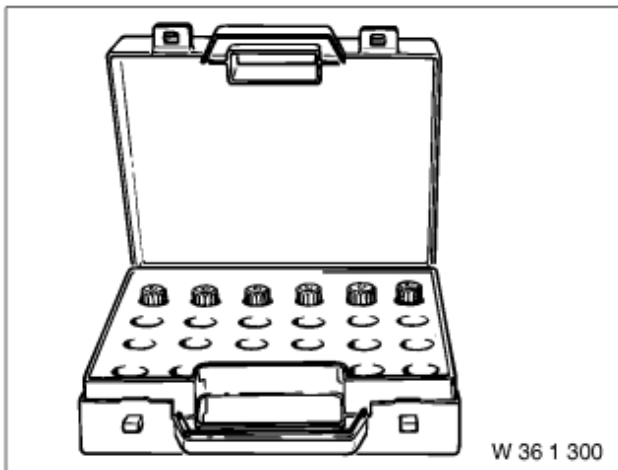

Common

Used in step [3](#)

Usage	(Code 33) With centring bore available separately (see EPC) under 36 13 6 765 546
Included in the tool or work	0 492 518
Storage location	
Replaced by	
In connection with	
SI-Number	

0 495 225 (36 1 327) Wheel bolt

Used in step [3](#)

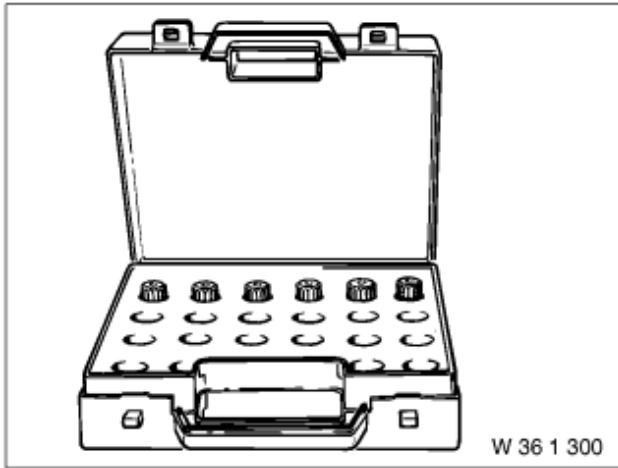

Common

Usage	(Code 34) With centring bore available separately (see EPC) under 36 13 6 765 547
Included in the tool or work	0 492 518
Storage location	
Replaced by	
In connection with	
SI-Number	

0 495 226 (36 1 328) Wheel bolt

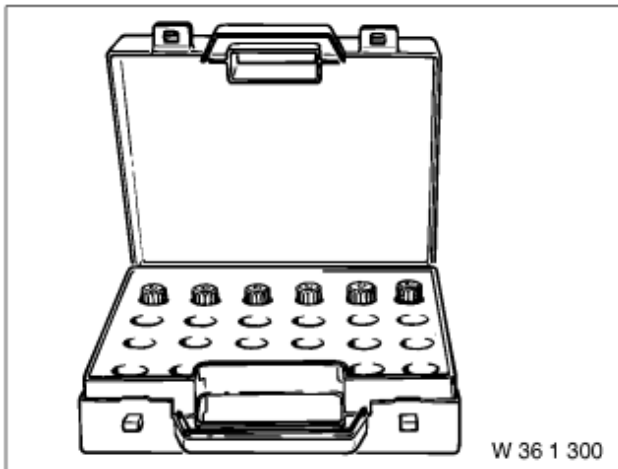

Common

Used in step **3**

Usage	(Code 35) With centring bore available separately (see EPC) under 36 13 6 762 340
Included in the tool or work	0 492 518
Storage location	
Replaced by	
In connection with	
SI-Number	

0 495 227 (36 1 329) Wheel bolt

Used in step **3**

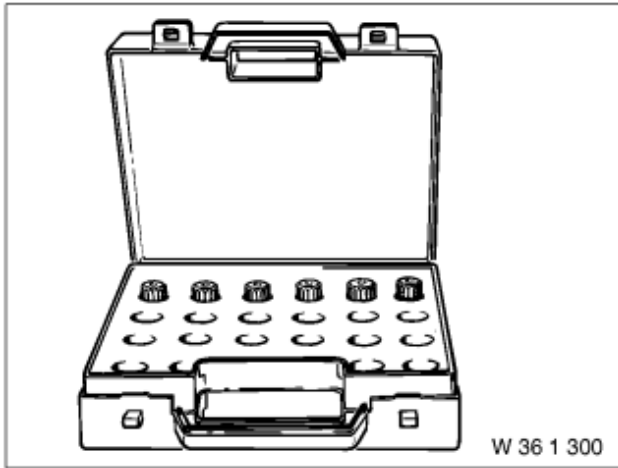

Common

Usage	(Code 36) With centring bore available separately (see EPC) under 36 13 6 762 341
Included in the tool or work	0 492 518
Storage location	
Replaced by	
In connection with	
SI-Number	

0 495 228 (36 1 331) Wheel bolt

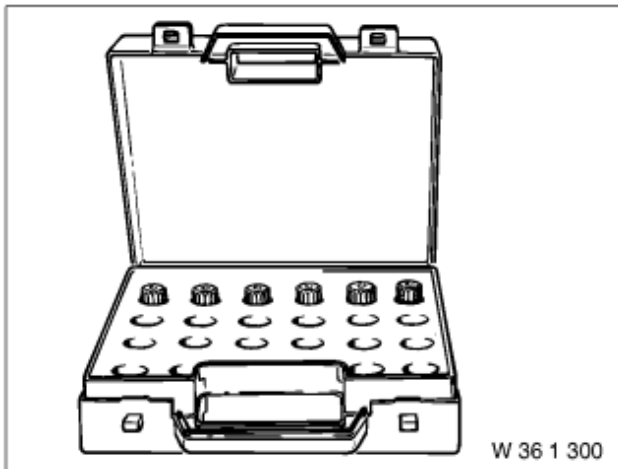

Common

Used in step **3**

Usage	(Code 37) With centring bore available separately (see EPC) under 36 13 6 762 342
Included in the tool or work	0 492 518
Storage location	
Replaced by	
In connection with	
SI-Number	

0 495 229 (36 1 332) Wheel bolt

Used in step **3**

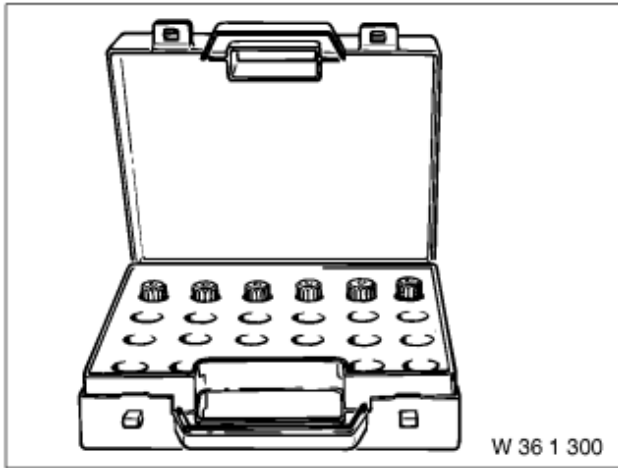

Common

Usage	(Code 38) With centring bore available separately (see EPC) under 36 13 6 762 343
Included in the tool or work	0 492 518
Storage location	
Replaced by	
In connection with	
SI-Number	

0 495 230 (36 1 333) Wheel bolt

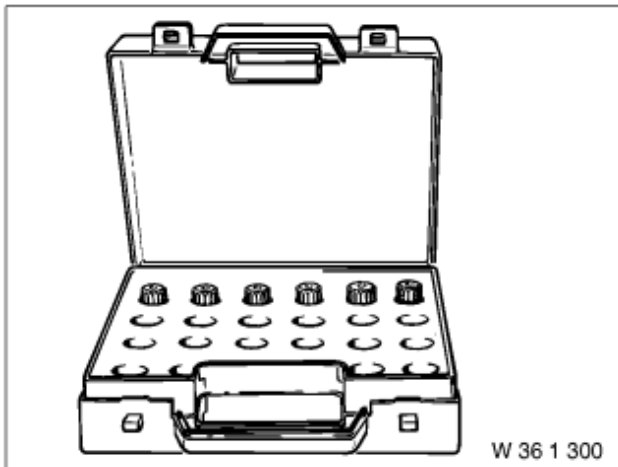

Common

Used in step [3](#)

Usage	(Code 40) With centring bore available separately (see EPC) under 36 13 6 762 344
Included in the tool or work	0 492 518
Storage location	
Replaced by	
In connection with	
SI-Number	

Links

Repair instructions

Used in step

[00 02 001 Raise the vehicle using a vehicle lift](#)

3 8

Parts required

Designation

Used in step

Screws

6

Hose clamp

6

For informational purposes only. The information on this website is provided AS-IS with no warranties, express or implied, and is not guaranteed to be error-free, up-to-date or complete. NewTIS and BMW assume no liability for any loss or damage arising from the use or reliance on the information and content on this website. The content on this website is subject to change without notice.